

---

# USE AND CARE GUIDE

---

## Country Garden® Porch Swing

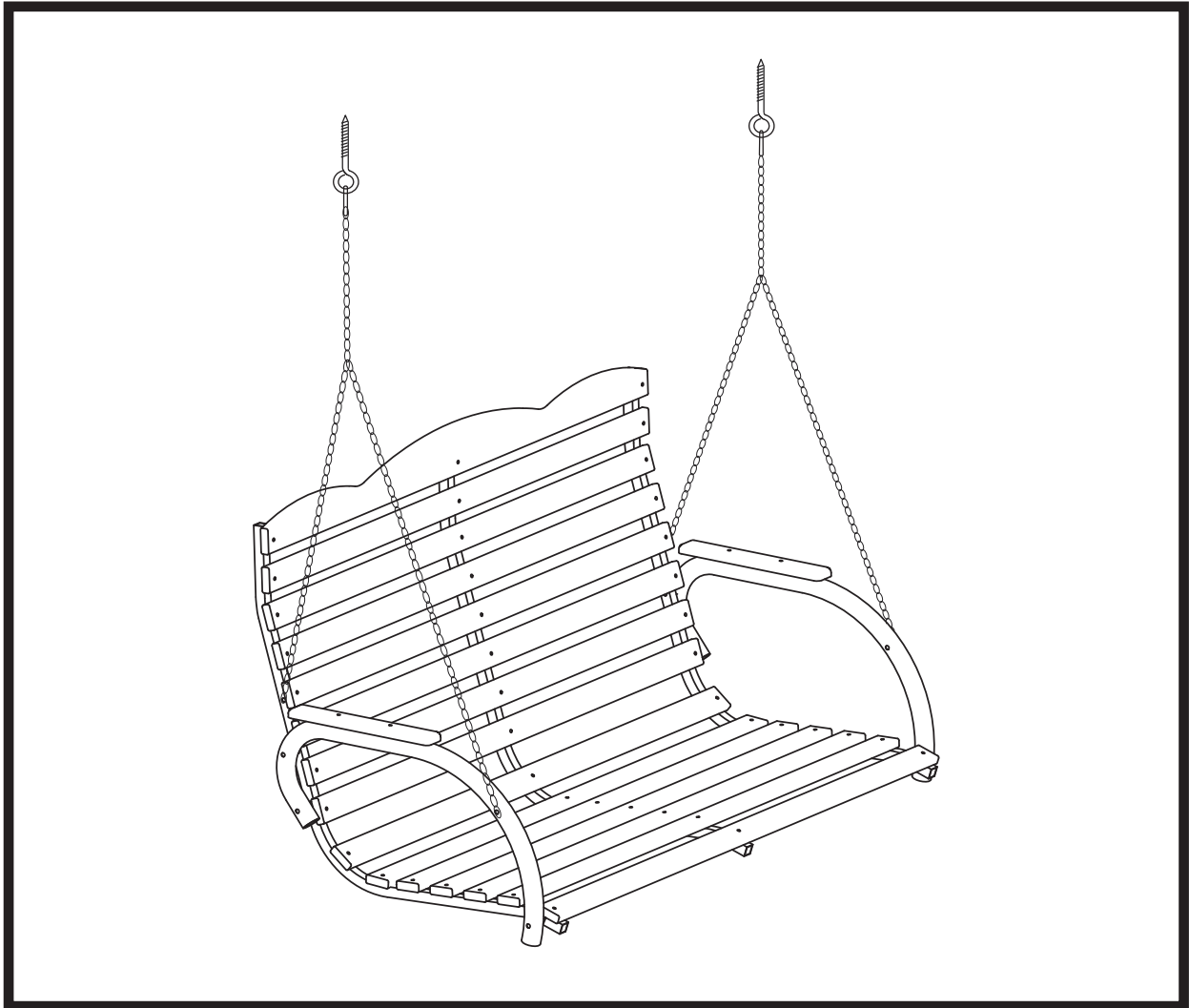

Questions, problems, missing parts?  
Please call Customer Service: 1-800-800-4950

warranty



## Contents

Do Not Return .....	03
Use & Care / Wood Care Guide.....	04
Instructions .....	05
Customer Service Contact Info.....	13

**DO NOT RETURN THIS ITEM TO THE STORE**

If you experience any difficulty with assembly, missing parts or use,  
please **DO NOT** return this item to the store.

Retail stores are unable to properly assist you.

Contact our **Customer Service Department** directly for assistance.

Call toll-free **1-800-800-4950**, Monday-Friday, between  
the hours of 8 a.m. and 8 p.m. (EST).

Our friendly Customer Service Agents will be happy to assist you.

---

---

# USE & CARE

---

## WARNINGS:

---

THIS PRODUCT DESIGNED FOR A MAXIMUM CAPACITY OF 500 POUNDS.

NOTE: Save assembly instruction sheet for future reference.

## OIL-BASED PAINTED WOOD CARE GUIDE

---

### **PLEASE READ THIS INFORMATION CAREFULLY - IT WILL HELP YOU TO MAINTAIN YOUR FURNITURE**

---

This furniture has been made from seasoned wood and has already been factory primed and finished with an oil-based paint. With proper maintenance, it will give you years of enjoyable service. Wood is a natural material and its appearance will change when exposed to the elements; surface splits and checking may appear, particularly on the end grain and to a lesser extent on the surface within a few weeks if left exposed to the elements. The furniture is designed with this in mind to remain strong and durable. If left exposed to the weather, your furniture will fade in color. The exact color will depend on the environment; for example, less fading will occur if the furniture is placed in a shady location under a tree. To help preserve the color, cover the furniture with a garden furniture cover when not in use. Wood expands and contracts with changes in relative humidity. To prevent over drying and excessive cracking, do not store in a heated place.

### CARE AND MAINTENANCE

---

1. We recommend cleaning the surface of dirt, bird droppings, tree sap, grease. etc. Scrub with a cloth or soft brush using a mild household cleaner, dish or laundry detergent.
2. Rinse thoroughly.
3. Allow to dry completely and retighten all hardware.

### REFINISHING

---

Based on exposure to the elements the finish may need to be restored. Proceed as follows:

1. Cover the floor area with a suitable liquid resistant ground sheet to contain dust, dirt or spills.
2. Use suitable protective clothing, i.e., rubber gloves, apron, safety glasses, dust mask, etc.
3. Check and retighten all furniture hardware
4. Remove any finish that has become loose or cracked by using a scraper or wire brush. **DO NOT USE STEEL WOOL** as the fine particles may result in dark rusty blotching.
5. In a well-ventilated area or outdoors, lightly sand using 100-200 grit sand paper.
6. Remove any dust by wiping with a damp cloth.
7. Allow item to dry completely.
8. Use an oil-based primer on any bare wood spots.
9. Brush or spray on new finish using the manufacturer's instructions – using an oil-based paint available at any paint retailer.

---

**Hardwood Porch Swing . Siège de balançoire . Columpio**

---

**Assembly Instructions – CG-47**  
**Instrucciones de armado – CG-47**  
**Instructions d'assemblage – CG-47**

Open outer hardware bag HB-4060 . Do not open inner bags until instructed.

Abra la bolsa exterior de ferretería HB-4060 . No abra las bolsas internas hasta que se le indique.

Ouvrez le sac de quincaillerie extérieure HB-4060. N'ouvrez pas les sacs intérieurs avant que ceci ne soit indiqué.

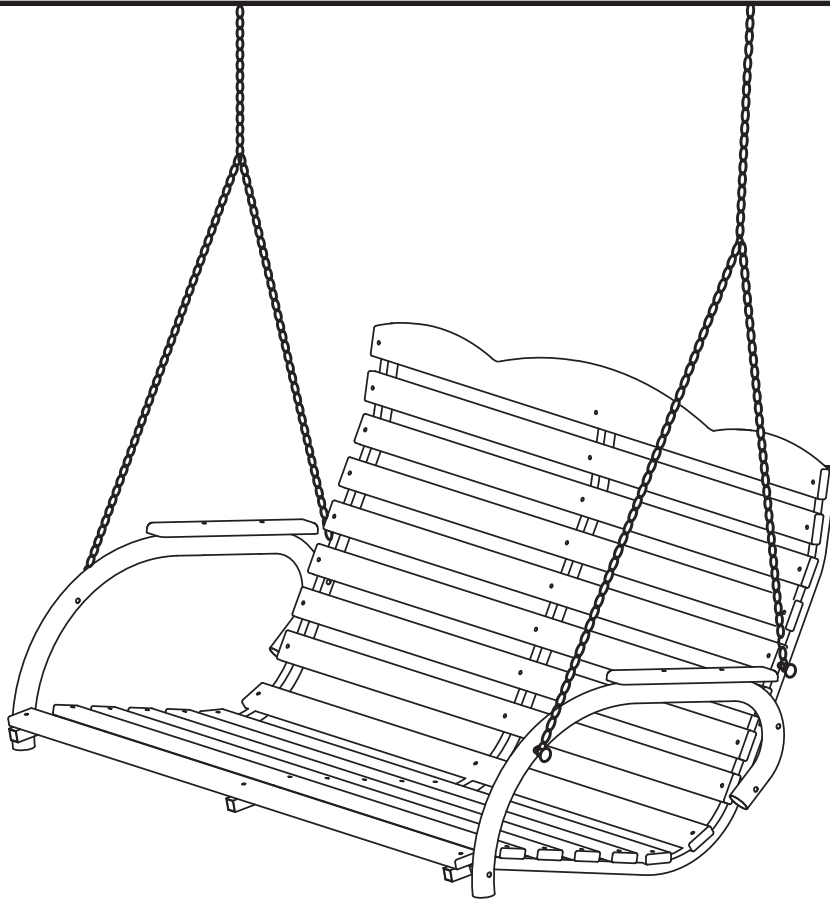

**Protected by U.S. Patent No. Des.405,278.**  
**Bajo Patente Americana No. Des. 405, 278.**  
**Protected by U.S. Patent No. Des.405,278.**

**IMPORTANT**

UNLESS NOTED, DO NOT TIGHTEN ANY BOLTS UNTIL LAST STEP.

**IMPORTANTE**

A MENOS QUE SE LE INDIQUE, NO APRIETE NINGÚN PERNO HASTA EL ÚLTIMO PASO.

**IMPORTANT**

À MOINS D'INDICATION CONTRAIRE, NE RESSERREZ PAS LES BOULONS AVANT LA DERNIÈRE ÉTAPE.

**TOOLS . HERRAMIENTAS . OUTIL**

You will need the following tools: hammer, screwdriver, 7/16" wrench, or adjustable wrench and pliers.  
Necesitará las siguientes herramientas: martillo, destornillador, llave de 7/16" o llave ajustable y pinzas.  
Vous aurez besoin des outils suivants : marteau, tournevis, clé de 7/16 po ou clé réglable et pinces.

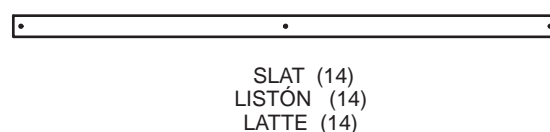
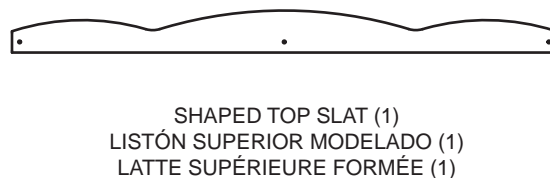
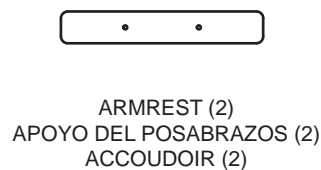
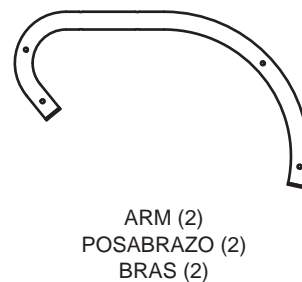
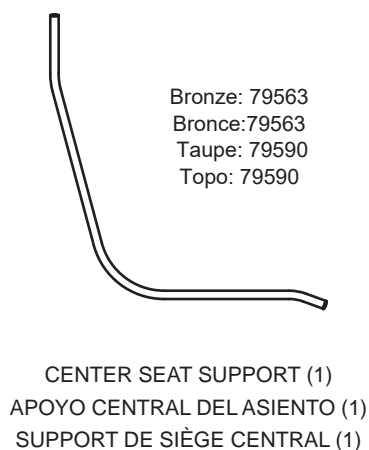
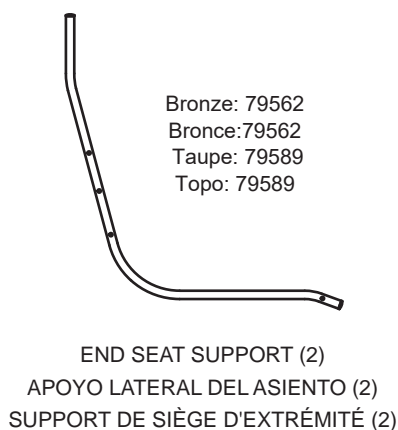
**LARGE PARTS (NOT TO SCALE)****PIEZAS GRANDES (NO A ESCALA)****PIÈCES GRANDES (PAS À L'ÉCHELLE)**

**HARDWARE PARTS LIST (SHOWN TO SCALE)**

\*Standard hardware items may be replaced locally.

**LISTA DE PIEZAS DE FERRETERÍA (SE MUESTRAN A ESCALA)**

\*Los artículos estándar de ferretería se pueden reemplazar en forma local.

**LISTE DE PIÈCES DE QUINCAILLERIE (À L'ÉCHELLE)**

\*Les articles de quincaillerie standard peuvent être remplacés localement.

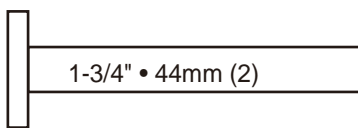
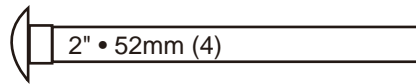
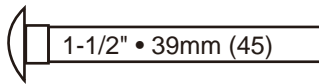

FLAT HEAD BOLT  
PERNO DE CABEZA PLANA  
BOULON À TÊTE PLATE

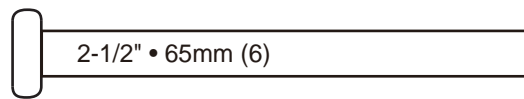

FLAT HEAD BOLT  
PERNO DE CABEZA PLANA  
BOULON À TÊTE PLATE

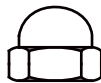

ACORN NUT (27)  
TUERCA CIEGA (27)  
ÉCROU BORGNE (27)



LOCKNUT (10)  
CONTRATUERCA (10)  
CONTRE-ÉCROU (10)



METAL SPACER (4)  
SEPARADOR DE METAL (4)  
ENTRETOISE DE MÉTAL (4)



HEX NUT (22)  
TUERCA HEXAGONAL (22)  
ÉCROU HEX. (22)



WASHER (2)  
ARANDELA (2)  
RONDELLE (2)



SQUARE PLASTIC SPACER (6)  
SEPARADOR CUADRADO DE PLÁSTICO (6)  
ENTRETOISE CARRÉE DE PLASTIQUE (6)

**CHAIN BAG (NOT TO SCALE)**

**BOLSA DE CADENA (NO A ESCALA)**

**SAC DE CHAÎNE (PAS À L'ÉCHELLE)**



CHAIN (2)  
CADENA (2)  
CHAÎNE (2)

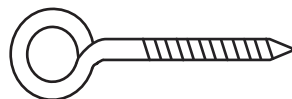

EYEBOLT (2)  
TORNILLOS DE OJO (2)  
ÉCROUS A CEIL (2)



QUICK LINK (2)  
MOSQUETON (2)  
MOUSQUETON (2)

## STEP 1 Open inner hardware bag IB-4050.

Attach the shaped top seat slat to the top of the three seat supports and a seat slat to the front using the hardware shown. The two end seat supports have 3 holes on the side. The center seat support does not have side holes.

Tap bolt heads into holes in slats until fully seated.

Fasten the top 9 slats on all three seat supports with acorn nuts and the bottom 6 with hex nuts.

## PASO 1 Abra la bolsa de ferretería interna IB-4050.

Una el listón superior modelado del asiento a la parte superior de los tres apoyos del asiento y un listón del asiento al frente usando la ferretería que se muestra. Los dos apoyos laterales del asiento tienen 3 orificios al costado. El apoyo central del asiento no tiene orificios laterales.

Golpee suavemente las cabezas de los pernos en los orificios de los listones hasta que estén totalmente apoyadas.

Ajuste los 9 listones superiores en los tres apoyos del asiento con tuercas ciegas y los 6 inferiores con tuercas hexagonales.

## ÉTAPE 1 Ouvrez le sac de quincaillerie intérieure IB-4050.

Fixez la latte supérieure du siège formée sur le dessus des trois supports du siège et une latte de siège à l'avant avec la quincaillerie illustrée. Les deux supports de siège d'extrémité ont 3 trous sur le côté. Le support du siège central n'a pas de trous latéraux.

Taraudez les têtes des boulons dans les trous des lattes jusqu'à ce qu'elles soient bien installées.

Fixez les 9 lattes supérieures sur les trois supports du siège avec les écrous borgnes et les 6 du bas avec les écrous hexagonaux.

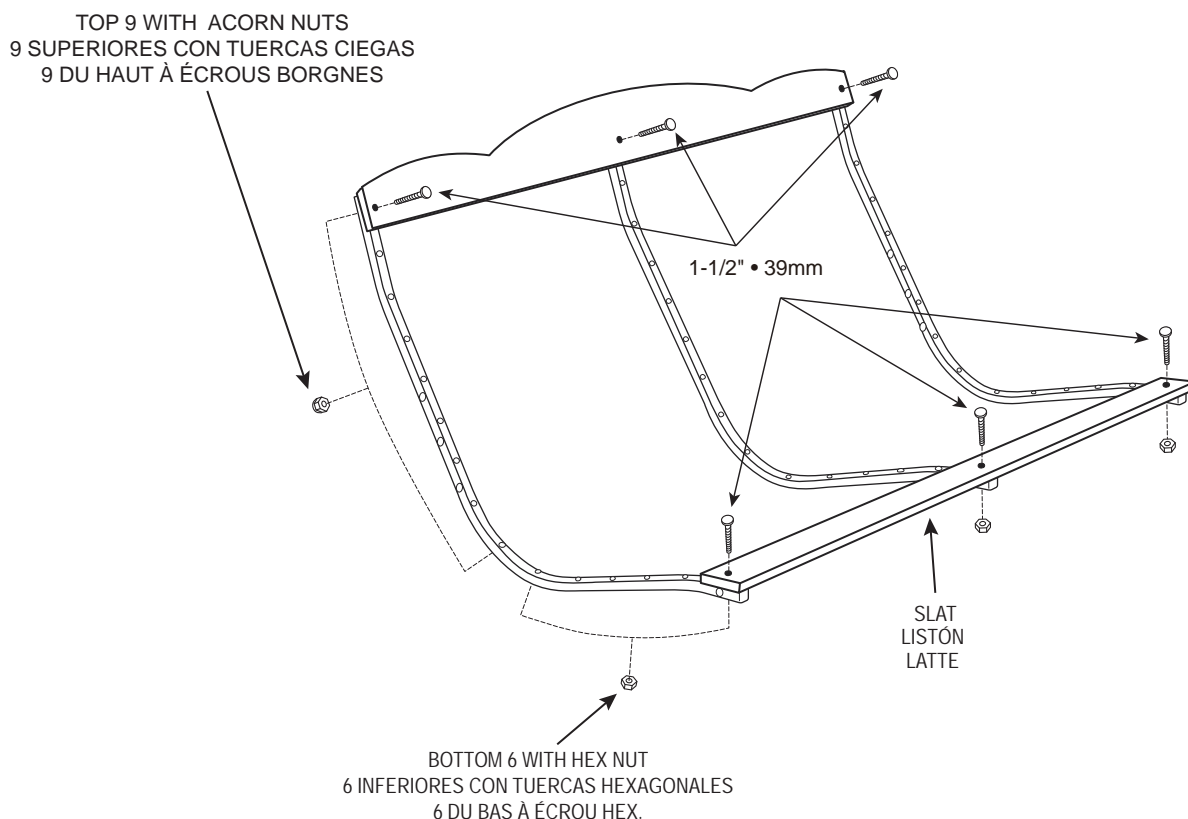

**DO NOT TIGHTEN HARDWARE!  
¡NO APRIETE LA FERRETERÍA!  
NE RESSERREZ PAS LA QUINCAILLERIE !**



**STEP 2** Open inner hardware bag IB-4120.  
Open plastic parts bag PP-4075.

Attach armrests to arms. Tap bolt heads until they are fully seated. Tighten bolts.  
Attach arms to seat using hardware shown.  
DO NOT TIGHTEN UNTIL COMPLETION OF STEP 5.

**PASO 2** Abra la bolsa de ferretería interna IB-4120.  
Abra la bolsa plástica PP-4075.

Una los apoyos de los posabrazos a los posabrazos. Golpee suavemente las cabezas de los pernos hasta que queden totalmente apoyadas. Apriete los pernos. Una los posabrazos al asiento usando la ferretería que se muestra.  
NO APRIETE HASTA NO COMPLETAR EL PASO 5.

**TAPE 2** Ouvrez le sac de quincaillerie intérieur IB-4120.  
Ouvrez le sac de plastique PP-4075.

Fixez les accoudoirs aux bras. Taraudez les têtes des boulons jusqu'à ce qu'elles soient bien installées. Resserrez les boulons. Fixez les bras au siège avec la quincaillerie tel qu'illustré.  
NE RESSERREZ PAS AVANT LA FIN DE L'ÉTAPE 5.

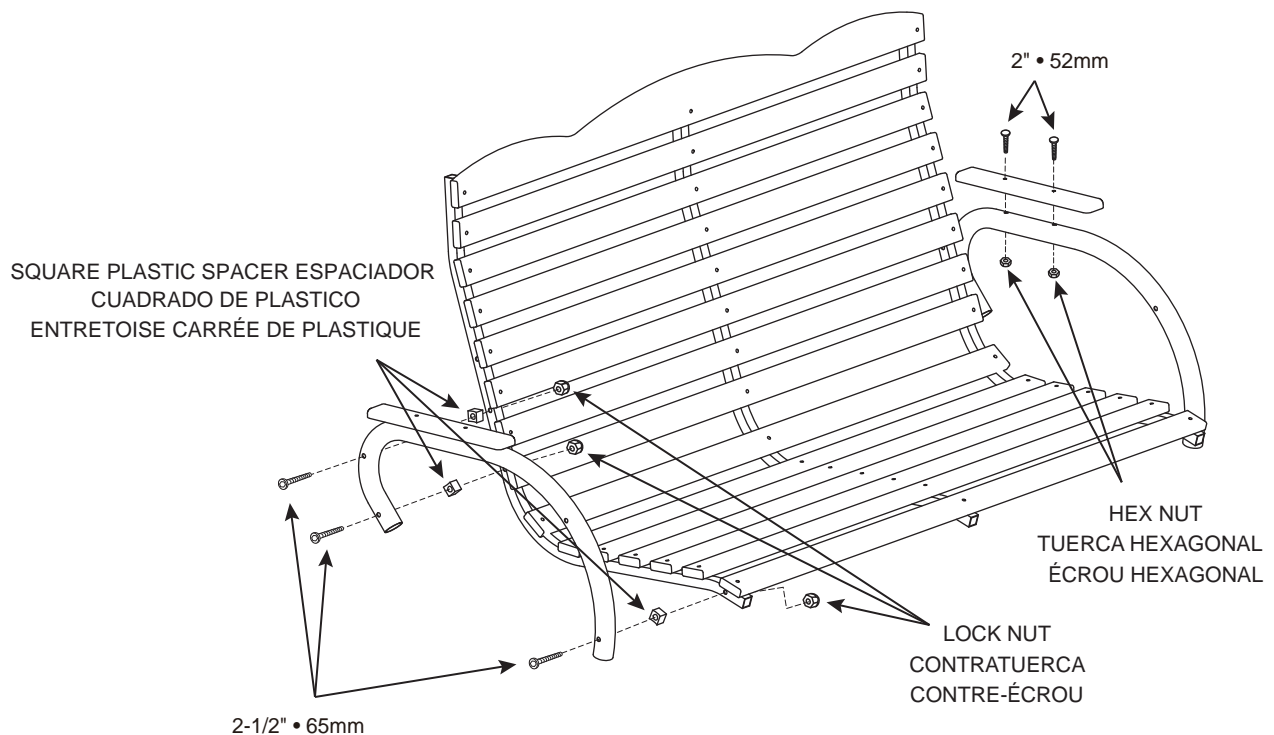

### STEP 3 Open inner hardware bag IB-4130. Open chain bag.

Attach chain with flathead bolts and hardware as shown. Each chain has 3 legs.  
Attach the 2 even lengths of chain as shown.

**!** Before using the chain, inspect each link in the chain to make sure all are tightly wound and secure. Failure of the chain could cause serious injury. Should any defect be found, contact Customer Service for a free replacement.

### PASO 3 Abra la bolsa de ferretería interna IB-4130. Abra la bolsa de la cadena.

Una la cadena con los pernos de cabeza plana y la ferretería que se muestra. Cada cadena tiene 3 extremos.  
Una los 2 largos iguales de la cadena como se muestra.

**!** Antes de usar la cadena, inspeccione cada eslabón de la misma para asegurarse de que todos estén firmemente unidos y seguros. La falla de la cadena puede causar lesiones graves. Si encuentra algún defecto, póngase en contacto con el Servicio de atención al cliente para obtener un repuesto gratis.

### ÉTAPE 3 Ouvrez le sac de quincaillerie intérieur IB-4130. Ouvrez le sac de la chaîne.

Fixez la chaîne avec les boulons à tête plate et la quincaillerie, tel qu'illustré. Chaque chaîne a 3 pattes. Fixez les 2 longueurs uniformes de la chaîne, tel qu'illustré.

**!** Avant d'utiliser la chaîne, inspectez chaque maillon de la chaîne pour vous assurer qu'ils soient bien installés. Toute défaillance de la chaîne pourrait causer de graves blessures. Si vous trouvez des défaillances, contactez le service à la clientèle pour un remplacement gratuit.

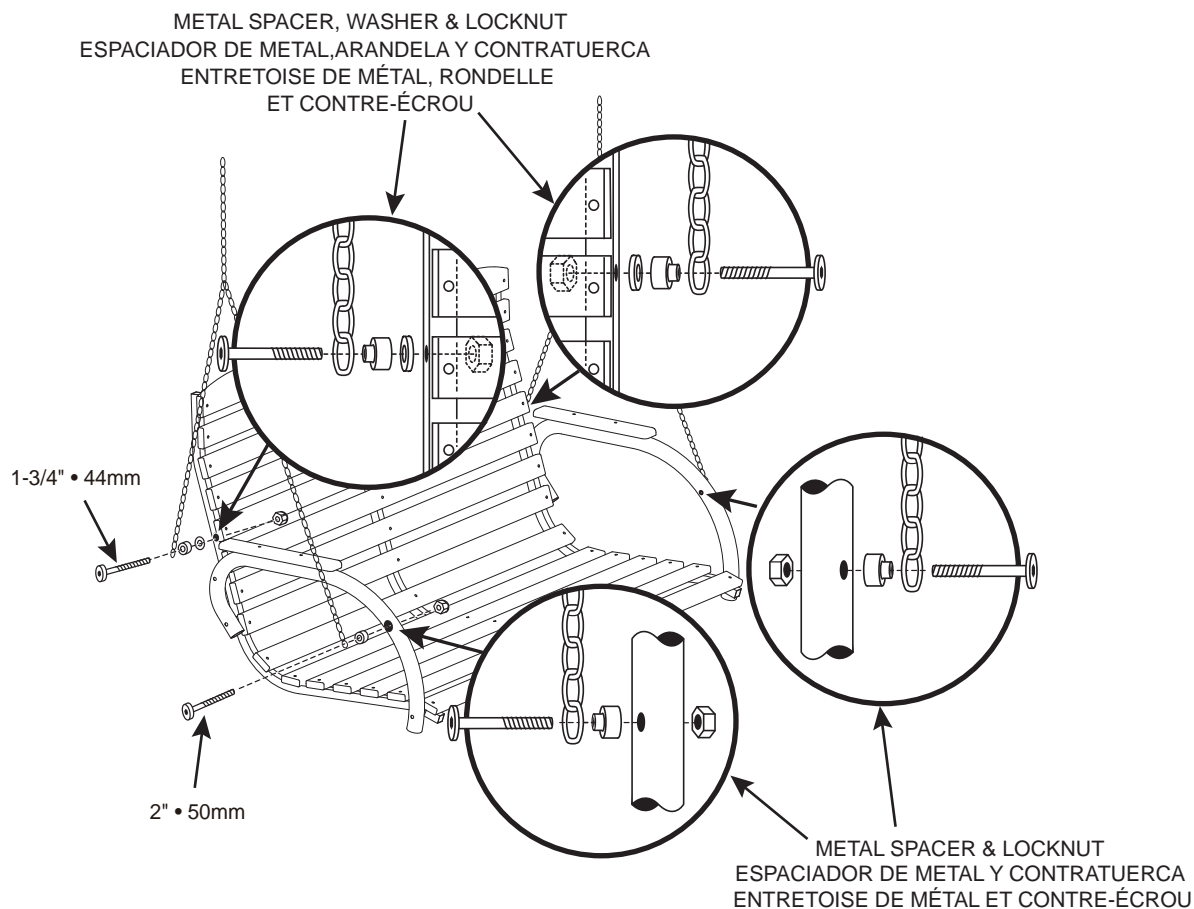

## STEP 4

The Chain Bag contains two ceiling hooks. These hooks should be screwed into overhead joists as shown in Figure A with a spacing of about 48". Note: If desired location of swing does not match overhead joist location, a suitable 2x4 header must first be attached to the joists and the ceiling hooks screwed into the header as shown in Figure B. It will be easier if you first drill a 1/4" diameter starter hole before installing the ceiling hooks. Turn ceiling hooks to the position shown so the lower portion moves freely with the motion of the swing seat.

## PASO 4

La bolsa de la cadena tiene dos tornillos de ojo que deben atornillarse en la parte de arriba de la viga con espacio aproximadamente de 48 pulgadas como se indica en la foto A. Nota: Si el querido lugar del balancín no coincide con la posición de los hoyos en la viga, primero agrega un barrote de madera de 2x4 y después atornilla los tornillos en el barrote como se indica en la foto B. Sera más fácil de hacer otras agujeros de ¼ de diámetro antes de instalar los tornillos de ojo. Atornilla los tornillos de ojo hasta que permiten el balancín de oscilar.

## ÉTAPE 4

La chaîne est accompagnée de deux écrous à oeil. Ces écrous doivent être vissés sur la poutre de soutien de plancher, espacées approximativement de 48 pouces, comme indiqués sur le schéma A. Note : Si l'emplacement désiré de la balancelle ne correspond pas à la position des trous sur la poutre, vous pouvez ajouter une planche à bois de 2x4 et la visser sur le plafond comme l'indique le schéma B. Il est plus facile de percer des trous de ¼ de diamètre avant de visser les écrous à oeil. Visser les écrous jusqu'à ce que la balancelle puisse se balancer librement .

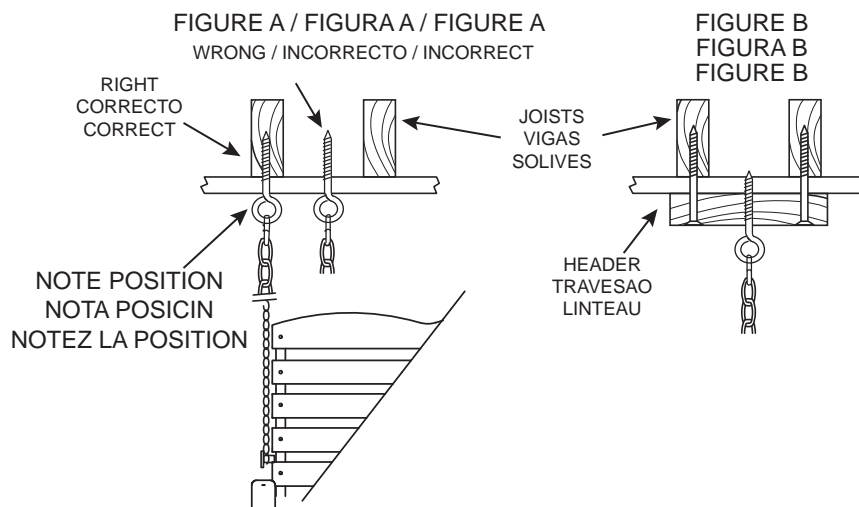

## STEP 5 / PASO 5 / ÉTAPE 5

Attach chain and swing to eyebolts using the quicklinks. Make sure the assembly is square.  
TIGHTEN ALL HARDWARE.

Usa el mosqueton para conectar la cadena y el balancin a los tornillos de ojos.

Asegúrese de que el ensamble esté en escuadra.

APRIETE TODOS LOS TORNILLOS .

Attacher le mousqueton a la chaine et l'ecrou. Vérifier que l'assemblage forme un carré.

VISSER FORTEMENT LES ECROUS .

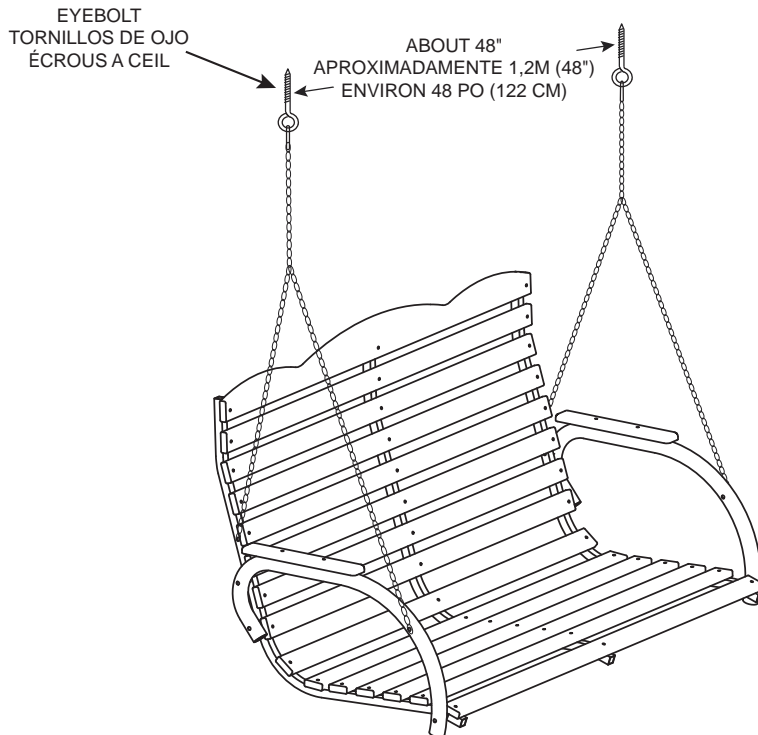



NOTE: The quick link is used to attach the chain to the eyebolt. In its open position, it should be passed through the chain and the eyebolt. The nut portion should be turned onto the threads completely; then tightened with pliers or a wrench.

NOTA: El mosquetón sirve para unir la cadena con el tornillo de ojo. Abierto, pasa el mosquetón en el eslabón de la cadena y en el ojo del tornillo. Después enrosca y apriete con pinzas o llave mecánica.

REMARQUE:

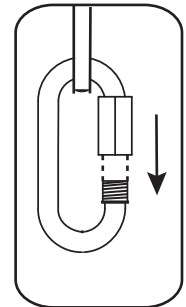
Le mousqueton sert à attacher l'écrou à la chaîne. Lorsqu'il est ouvert, accrocher le mousqueton à la chaîne et l'écrou. Visser le mousqueton et serrer à l'aide d'une pince ou clef universelle.



- 

Periodically check all hardware to make sure it is tightened and check chain and connecting hardware for excessive wear that could cause the swing to fall and result in serious injury.
- 

Examine periódicamente toda la ferretería para asegurarse de que esté apretada y examine la cadena y la ferretería de conexión en busca de desgaste en exceso que pueda hacer que el columpio caiga y resulte en lesiones graves.
- 

Vérifiez régulièrement toute la quincaillerie pour vous assurer qu'elle soit bien resserrée et vérifiez aussi la chaîne et la quincaillerie de connexion pour tout signe d'usure excessive qui pourrait faire défailir la balançoire et mener à de graves blessures.

## Customer Service

Questions, problems, missing parts?  
Please call Customer Service: 1-800-800-4950



For more information about warranty, please visit [WWW.JACK-POST.COM](http://WWW.JACK-POST.COM) / Warranty .

---

  
**JACK-POST**<sup>®</sup>  
CORPORATION  
800 East Third Street  
Buchanan, Michigan 49107-1803  
Customer Service 1-800-800-4950  
Mon. thru Fri. 8:00am – 8:00pm EST  
E-mail [cs@jack-post.com](mailto:cs@jack-post.com)  
English, Español, Français