

USE AND CARE GUIDE

Country Garden® Glider Tete-A-Tete

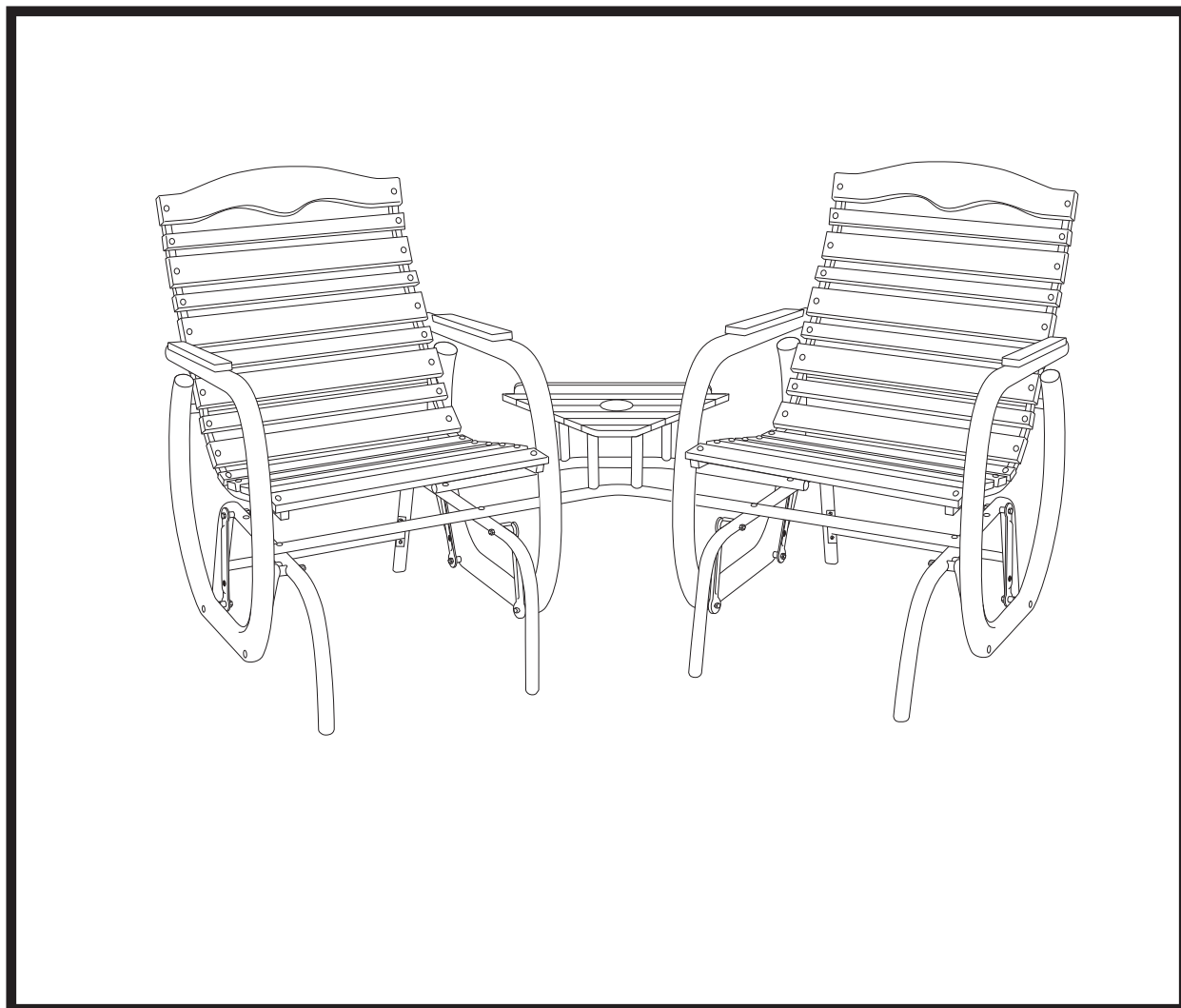

Questions, problems, missing parts?
Please call Customer Service: 1-800-800-4950

warranty



Contents

Do Not Return03

Use & Care /Wood Care Guide.....04

Instructions05

Customer Service Contact Info.....14

DO NOT RETURN THIS ITEM TO THE STORE

If you experience any difficulty with assembly, missing parts or use,
please **DO NOT** return this item to the store.

Retail stores are unable to properly assist you.

Contact our **Customer Service Department** directly for assistance.

Call toll-free **1-800-800-4950**, Monday-Friday, between
the hours of 8 a.m. and 8 p.m. (EST).

Our friendly Customer Service Agents will be happy to assist you.

USE & CARE

WARNINGS:

THIS PRODUCT DESIGNED FOR THE MAXIMUM WEIGHT CAPACITY OF 250 POUNDS PER SEAT .

NOTE: Save assembly instruction sheet for future reference.

OIL FINISH WOOD CARE GUIDE

PLEASE READ THIS INFORMATION CAREFULLY, IT WILL HELP YOU TO MAINTAIN YOUR FURNITURE

This furniture has been made from seasoned hard wood and has already been oiled prior to packaging.

Wood is a natural material and its appearance will change when exposed to the elements;

surface splits and checking may appear, particularly on the end grain and to a lesser extent on the surface within a few weeks if left exposed to the elements. This is normal for close-grained hard woods. The furniture is designed with this in mind to remain strong and durable. If left exposed to the weather your furniture will turn a silver grayish color, the exact color will depend on the environment; for example, dark spots may occur if the furniture is placed in a shady location under a tree. To help preserve the color cover the furniture with a garden furniture cover when not in use. Wood expands and contracts with changes in relative humidity, to prevent over drying and excessive cracking do not store in a heated place. To maintain the original timber color and to keep your surface in pristine condition we recommend applying an oil base penetrating finish such as deck stain which is available at most wood product retailers.

We DO NOT recommend surface coatings such as sealers, varnishes or water base products. If your furniture is in a fully exposed environment, we recommend re-coating 2 times per year. In a semi-covered environment (e.g. shade, covered patio or similar) we recommend coating once per year. Also, by applying the oil/stain before the wood begins to turn the characteristic silver/gray color following these simple instructions may lengthen the interval between recoating.

CARE AND MAINTENANCE

1. Cover the floor area with a suitable liquid resistant ground sheet to contain dust, dirt or spills.
2. Use suitable protective clothing, i.e. rubber gloves, apron etc.
3. Check and retighten all furniture hardware
4. Inspect the condition of all wood surfaces. The silver/gray color indicates the natural oxidation of the wood and may be accompanied by fine surface splits or checking. This is evidence of the wood's natural protection acting like our outer skin. Consequently, the natural weathered surface is only skin deep and the original color reappears when new wood is exposed.
5. To return the wood to its original color we recommend cleaning the surface of dirt, bird droppings, tree sap, grease etc. Scrub or brush with a mild detergent and rinse thoroughly. Ensure the wood surface is completely dry before finishing.
6. DO NOT USE STEEL WOOL as the fine particles may result in dark rusty blotching.

APPLYING THE OIL FINISH

7. After opening can of oil/stain stir thoroughly to produce an even consistency. We recommend the use of a lint free cloth or small brush suitable for oil base finishes.
8. Apply oil/stain evenly to all wood surfaces avoiding the oil/stain to pool. When finished, wipe off any runs or excess oil/stain. (Avoid applying too much oil/stain as a thin coat will give ample protection.) Any excess oil/stain may be cleaned with Mineral Spirits or Turpentine.
9. Allow appx. 48 hours for oil/stain to dry completely. Before use wipe away any residue using a lint free cloth and a household furniture polish. A buffing action may produce a slightly polished surface.

Country Garden® Glider Tete-A-Tete Mecedora Tete-A-Tete Country Garden® Fauteuil coulissant tête-à-tête Country Garden®

Assembly Instructions – Model CG-30 Instrucciones de armado – Modelo CG-30 Instructions d'assemblage – Modèle CG-30

Open outer hardware bag HB-4300 & Blister card . Do not open inner bags until instructed.

Abra la bolsa exterior de ferretería HB-4300 & Tarjeta blister . No abra las bolsas internas hasta que se le indique.

Ouvrez le sac de quincaillerie extérieure HB-4300 & Carte plastifiée . N'ouvrez pas les sacs intérieurs avant que ceci ne soit indiqué.

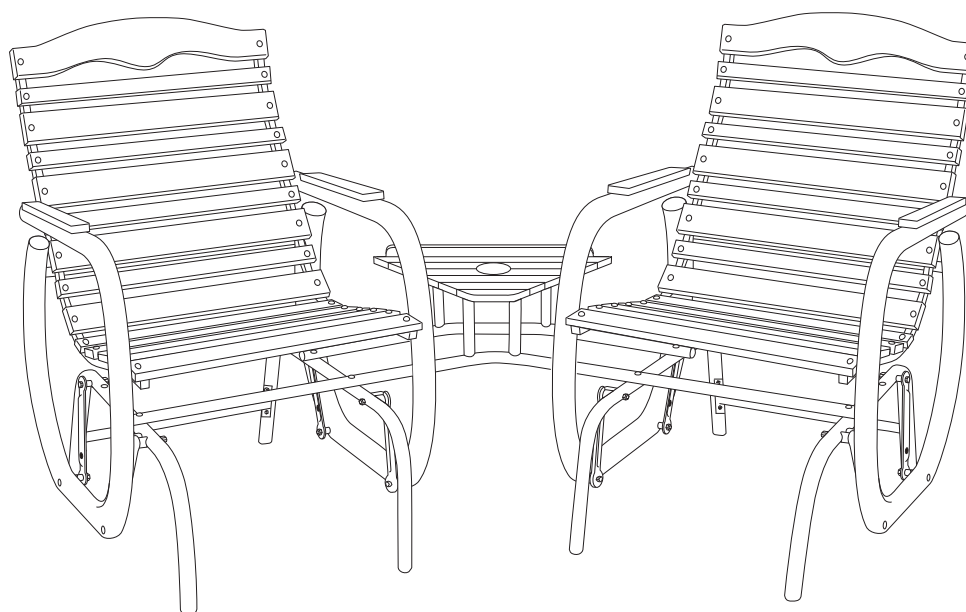

IMPORTANT

UNLESS NOTED, DO NOT TIGHTEN ANY BOLTS UNTIL LAST STEP.

IMPORTANTE

A MENOS QUE SE LE INDIQUE, NO APRIETE NINGÚN PERNO HASTA EL ÚLTIMO PASO.

IMPORTANT

À MOINS D'INDICATION CONTRAIRE, NE RESSERREZ PAS LES BOULONS AVANT LA DERNIÈRE ÉTAPE.

TOOLS . HERRAMIENTAS . OUTIL

You will need the following tools: screwdriver, 7/16" wrench, or pliers or adjustable wrench.

Necesitará las siguientes herramientas: destornillador, llave de 1,11 cm, o pinza o llave ajustable.

Vous aurez besoin des outils suivants : tournevis, clés de 1,11 cm, ou pinces ou clé réglable.

LARGE PARTS (NOT TO SCALE)**PIEZAS GRANDES (NO A ESCALA)****PIÈCES GRANDES (PAS À L'ÉCHELLE)**

SHAPED TOP SLAT (2)
LISTÓN SUPERIOR MODELADO (2)
LATTE SUPÉRIEURE FORMÉE (2)



WIDE SLAT (14)
LISTÓN ANCHO (14)
LATTE LARGE (14)



NARROW SLAT (14)
LISTÓN ANGOSTO (14)
LATTE ÉTROITE (14)

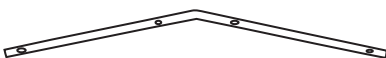

FRONT CONNECTOR (1)
CONECTOR DELANTERO (1)
CONNECTEUR AVANT (1)



SEAT BRACE (2)
TIRANTE DEL ASIENTO (2)
RENFORT DU SIÈGE (2)



REAR CONNECTOR (1)
CONECTOR TRASERO (1)
CONNECTEUR ARRIÈRE (1)



ARM REST (4)
APOYO DEL POSABRAZOS (4)
ACCOUDOIR (4)



BASE(4) BASE(4) BASE(4)

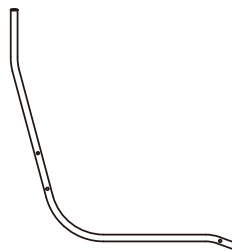

END SEAT SUPPORT (4)
APOYO LATERAL DEL ASIENTO (4)
SUPPORT DE SIÈGE D'EXTRÉMITÉ (4)

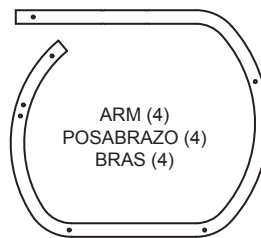

ARM (4)
POSABRAZO (4)
BRAS (4)



BEARING (8)
RODAMIENTO (8)
ROULEMENT (8)

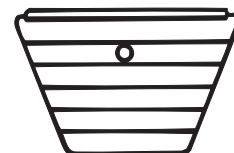

TRAY (1)
BANDEJA (1)
PLATEAU (1)

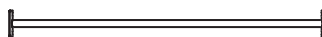

BASE BRACE (2)
TIRANTE DE LA BASE (2)
RENFORT DE LA BASE (2)



TRAY SUPPORT (4)
SOPORTE DE LA BANDEJA (4)
SUPPORT DE PLATEAU (4)

HARDWARE PARTS LIST (SHOWN TO SCALE)

*Standard hardware items may be replaced locally.

LISTA DE PIEZAS DE FERRETERÍA (SE MUESTRAN A ESCALA)

*Los artículos estándar de ferretería se pueden reemplazar en forma local.

LISTE DE PIÈCES DE QUINCAILLERIE (À L'ÉCHELLE)

*Les articles de quincaillerie standard peuvent être remplacés localement.

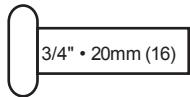

3/4" • 20mm (16)

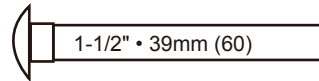

1-1/2" • 39mm (60)

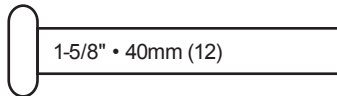

1-5/8" • 40mm (12)

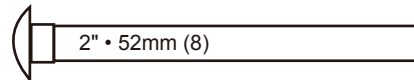

2" • 52mm (8)

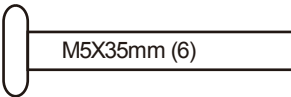

M5X35mm (6)

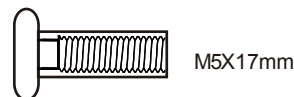

M5X17mm

NUT(6) TUERCA (6) ÉCROU (6)



LOCKNUT (16)
CONTRATUERCA (16)
CONTRE-ÉCROU (16)

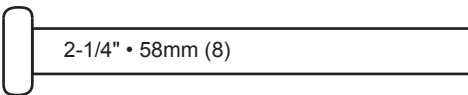

2-1/4" • 58mm (8)



HEX NUT (32)
TUERCA HEXAGONAL (32)
ÉCROU HEX (32)

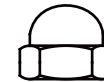

ACORN NUT (36)
TUERCA CIEGA (36)
ÉCROU BORGNE (36)

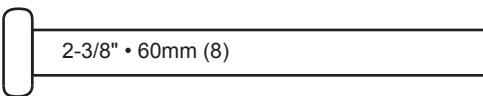

2-3/8" • 60mm (8)

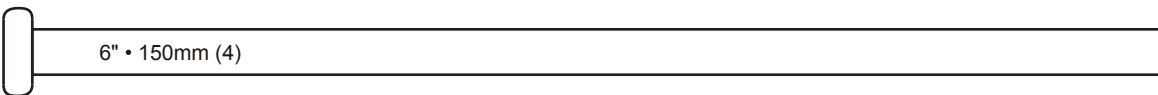

6" • 150mm (4)



PLASTIC PLUG (2)
TAPÓN PLÁSTICO (2)
BOUCHONS DEPLASTIQUE(2)



PLASTIC SPACER (16)
SEPARADOR PLÁSTICO (16)
ENTRETOISE DE PLASTIQUE (16)



SQUARE PLASTIC SPACER (12)
SEPARADOR CUADRADO DE PLÁSTICO (12)
ENTRETOISE CARRÉE DE PLASTIQUE (12)

TOOLS INCLUDED (NOT TO SCALE)

HERRAMIENTAS INCLUIDAS (NO A ESCALA)

OUTIL INCLURE (PAS À L'ÉCHELLE)



(2)

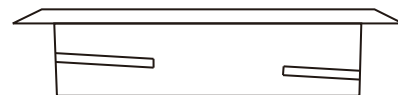

UMBRELLA HOLE PLUG (1)
TAPÓN DEL ORIFICIO PARA SOMBRILLA (1)
BOUCHON DU TROU DE PARASOL (1)

STEPS 1-4 SHOW THE ASSEMBLY OF EACH GLIDER CHAIR. ONCE THE FIRST CHAIR IS ASSEMBLED, REPEAT TO ASSEMBLE THE SECOND CHAIR.

LOS PASOS 1 A 4 MUESTRAN EL ARMADO DE CADA SILLA MECEDORA. UNA VEZ QUE LA PRIMERA SILLA ESTÉ ARMADA, REPITA LOS PASOS PARA ARMAR LA SEGUNDA SILLA.

LES ÉTAPES 1 À 4 MONTRENT L'ASSEMBLAGE DE CHAQUE FAUTEUIL COULISSANT. APRÈS AVOIR ASSEMBLÉ LE PREMIER FAUTEUIL, RÉPÉTEZ POUR LE DEUXIÈME.

STEP 1A Open blister card and plastic parts bag PP-4300 .

Attach base braces to bases with hardware shown.

PASO 1 A

Instale los tirantes de la base a las bases con la ferretería que se muestra.

ÉTAPE 1A

Fixez les cales de base aux bases avec la quincaillerie indiquée.

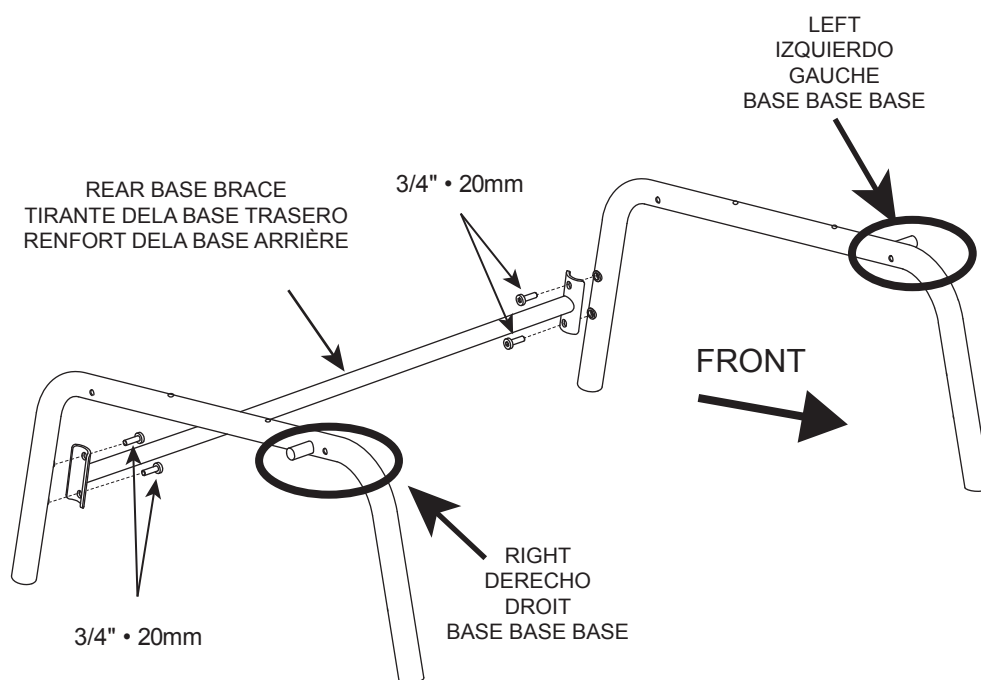

STEP 1B

Attach bearing assemblies to base using hardware and plastic spacers shown.

PASO 1 B

Instale los ensambles de los rodamientos a la base usando la ferretería y los separadores plásticos que se muestran.

ÉTAPE 1B

Fixez les assemblages de roulement à la base avec la quincaillerie et les entretoises de plastique indiquées.

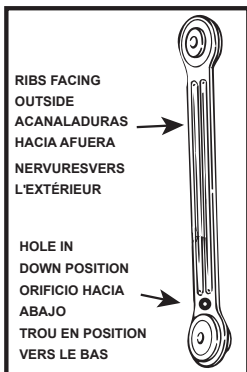
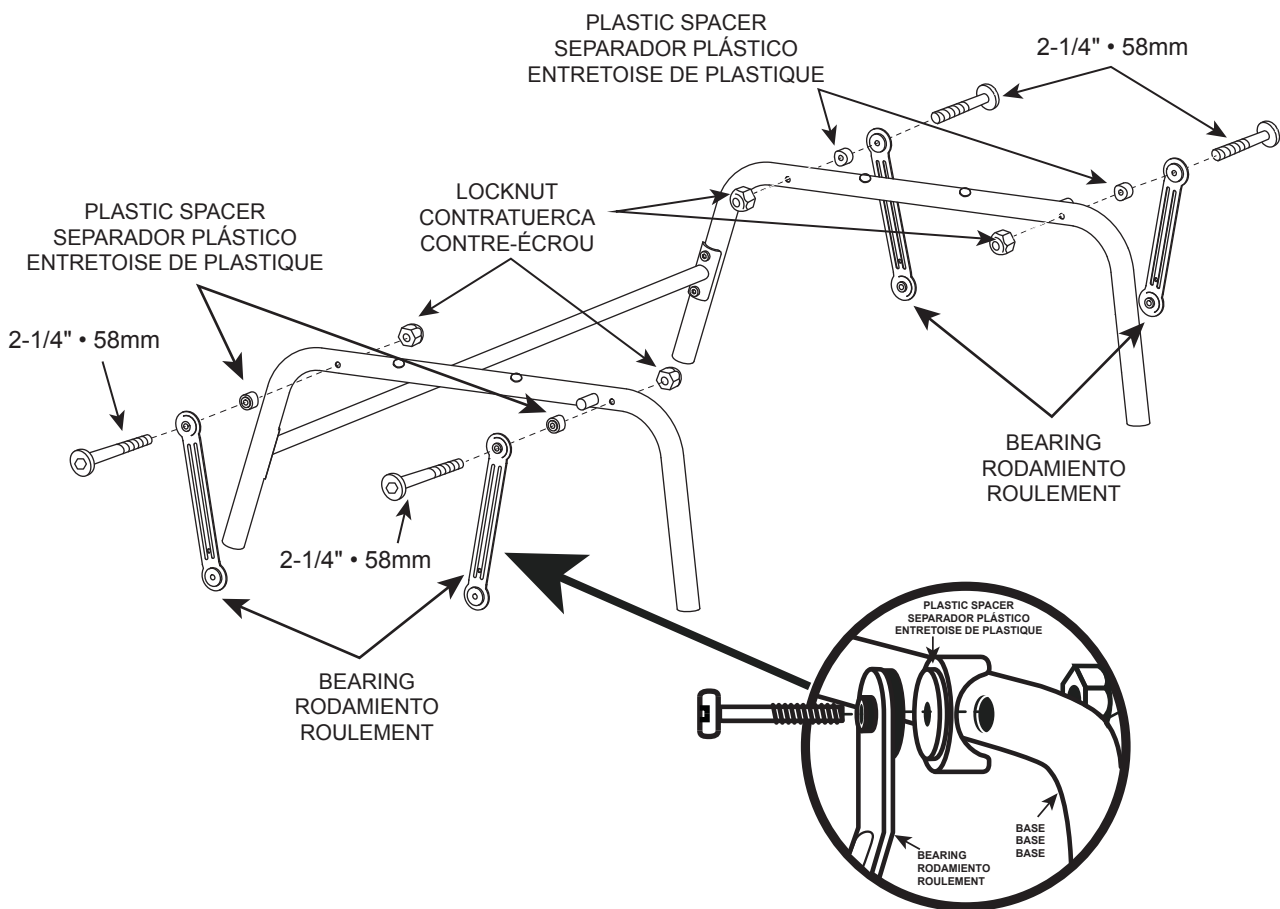

IMPORTANT NOTE:
On both sides of the glider, the two (2) protruding ribs on the bearing assembly must face outward and the hole must be at the bottom.

NOTA IMPORTANTE:
En ambos lados de la mecedora, las 2 (dos) acanaladuras que sobresalen en el ensamble del rodamiento deben estar hacia afuera y el orificio debe estar en la parte inferior.

REMARQUE IMPORTANTE :
Des deux côtés du patin, les deux (2) nervures sortantes sur l'assemblage de roulement doivent faire face vers l'extérieur et le trou doit être au bas.

Do not overtighten! Two (2) threads should extend beyond the nylon in the end of the nut. Bearing should move freely.

¡No apriete en exceso!
Deben quedar 2 (dos) roscas sobresaliendo del nilón en el extremo de la tuerca. El rodamiento debe moverse libremente.

Ne resserrez pas trop !
Deux (2) filets doivent sortir au-delà du nylon à la fin de l'écrou. Le roulement doit se déplacer librement.

STEP 2 Open blister card , inner hardware bag IB-4301 and plastic parts bag PP-4300.

Attach 2 arm rests with hardware shown. Attach seat brace to arms using hardware shown. Attach end seat supports to arms with hardware shown.

DO NOT TIGHTEN HARDWARE.

PASO 2

Una los 2 apoyos de los posabrazos con la ferretería que se muestra. Una el tirante del asiento a los posabrazos con la ferretería que se muestra. Una los apoyos laterales del asiento a los posabrazos con la ferretería que se muestra.

NO APRIETE LA FERRETERÍA.

ÉTAPE 2

Fixez les 2 accoudoirs avec la quincaillerie indiquée. Fixez le renfort du siège aux accoudoirs avec la quincaillerie indiquée. Fixez les supports d'extrémité du siège aux bras avec la quincaillerie indiquée.

NE RESSERREZ PAS LA QUINCAILLERIE.

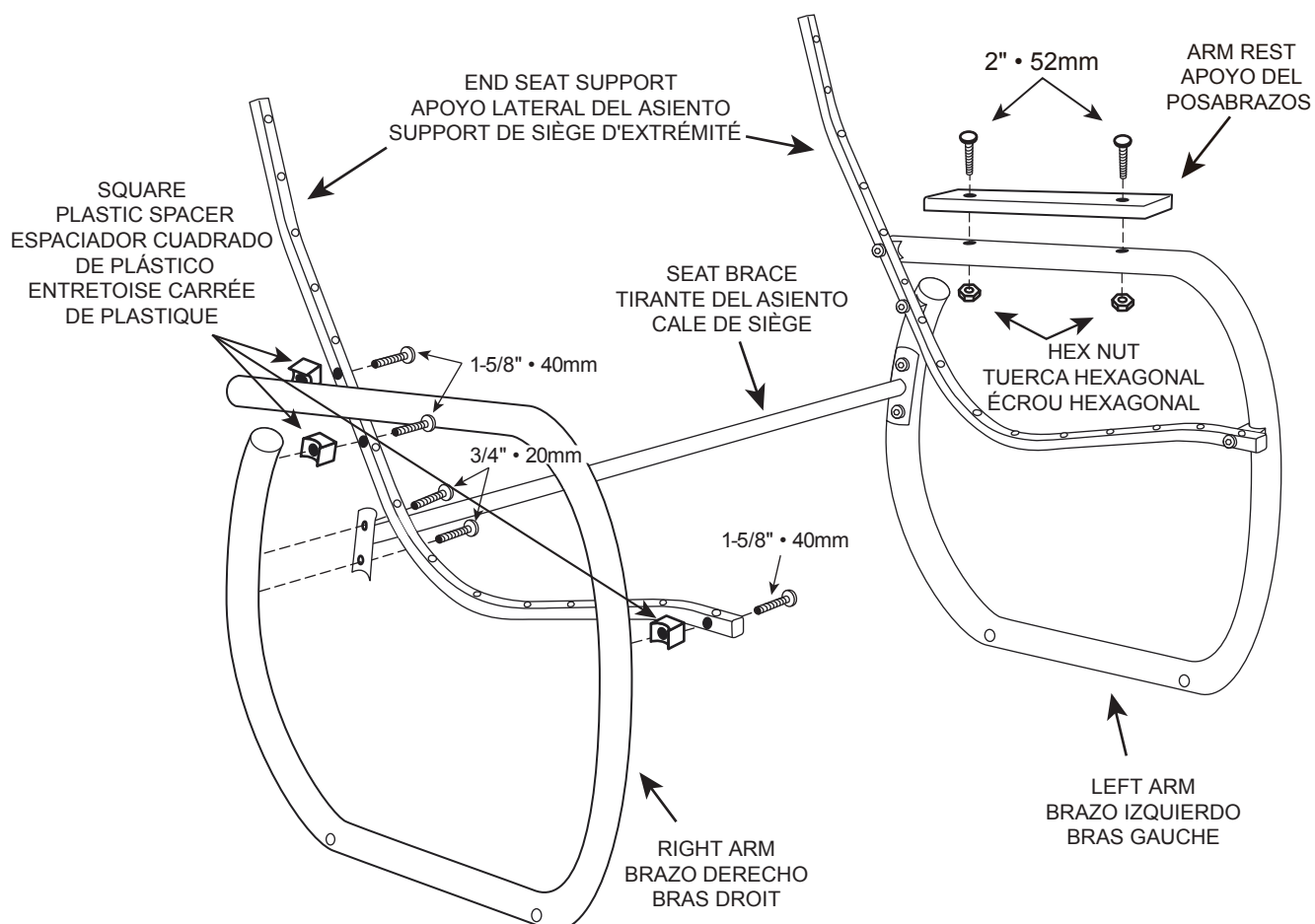

STEP 3 Open inner hardware bag IB-4301 .

Attach the shaped top seat slat to the top of the 2 seat supports and a wide slat to the front using the hardware shown. Tap bolt heads into holes in slats until fully seated.

Fasten the top 9 slats on all 3 seat supports with acorn nuts and the bottom 6 with hex nuts.

MAKE SURE THE ASSEMBLY IS SQUARE. TIGHTEN ALL HARDWARE.

PASO 3

Una el listón superior modelado del asiento a la parte superior de los 2 apoyos del asiento y un listón ancho al frente usando la ferretería que se muestra.

Golpee las cabezas de los pernos en los orificios de los listones hasta que estén totalmente asentadas.

Ajuste los 9 listones superiores en los 3 apoyos del asiento con tuercas ciegas y los 6 inferiores con tuercas hexagonales.

ASEGÚRESE DE QUE EL ENSAMBLE ESTÉ EN ESCUADRA. APRIETE TODA LA FERRETERÍA.

ÉTAPE 3

Fixez la latte supérieure du siège formée sur le dessus des 2 supports du siège et une latte large à l'avant avec la quincaillerie indiquée.

Taraudez les têtes des écrous dans les trous des lattes jusqu'à ce qu'elles soient bien installées.

Fixez les 9 lattes supérieures sur les trois supports du siège avec les écrous borgnes et les 6 du bas avec les écrous hexagonaux.

ASSUREZ-VOUS QUE L'ASSEMBLAGE SOIT D'ÉQUERRE. RESSERREZ TOUTE LA QUINCAILLERIE.

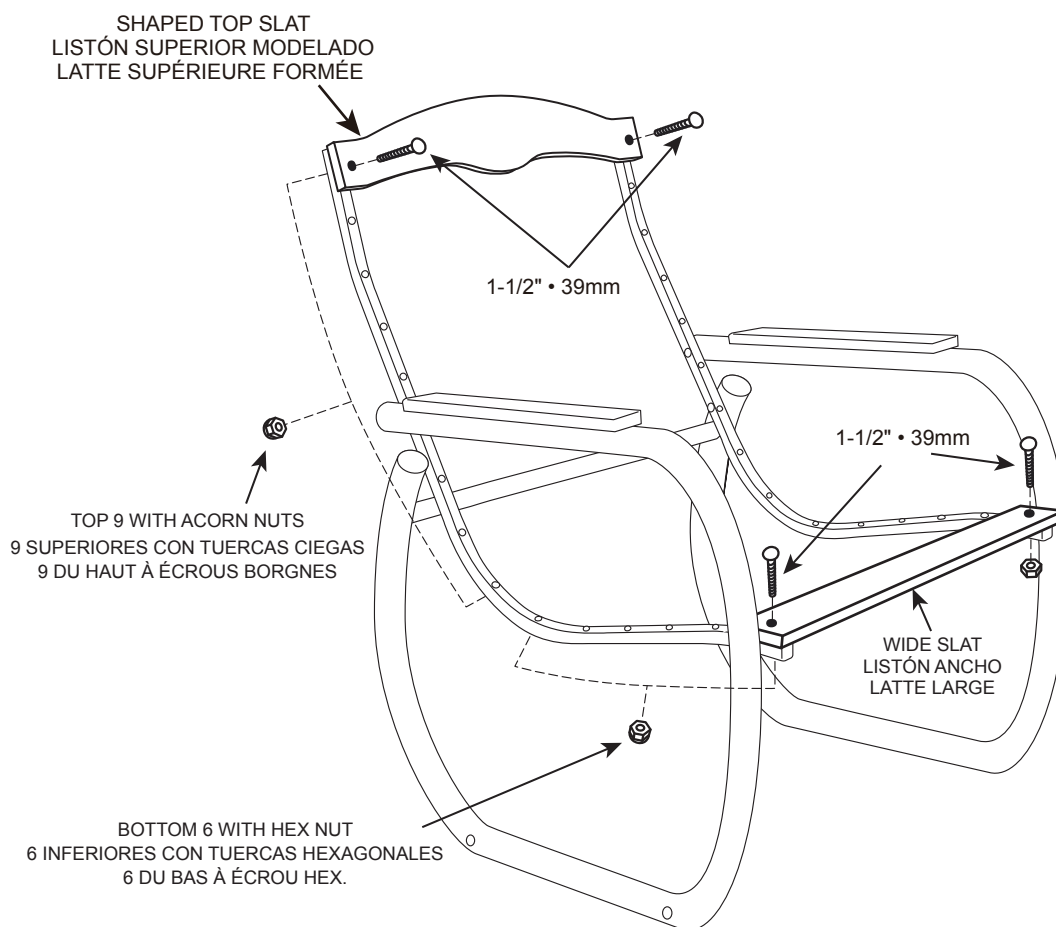

STEP 4 Open blister card and plastic parts bag PP-4300.

Attach seat to base using hardware shown.
TIGHTEN HARDWARE.

PASO 4

Una el asiento a la base usando la ferretería que se muestra.
APRIETE LA FERRETERÍA.

ÉTAPE 4

Fixez le siège à la base avec la quincaillerie indiquée.
RESSERREZ LA QUINCAILLERIE.

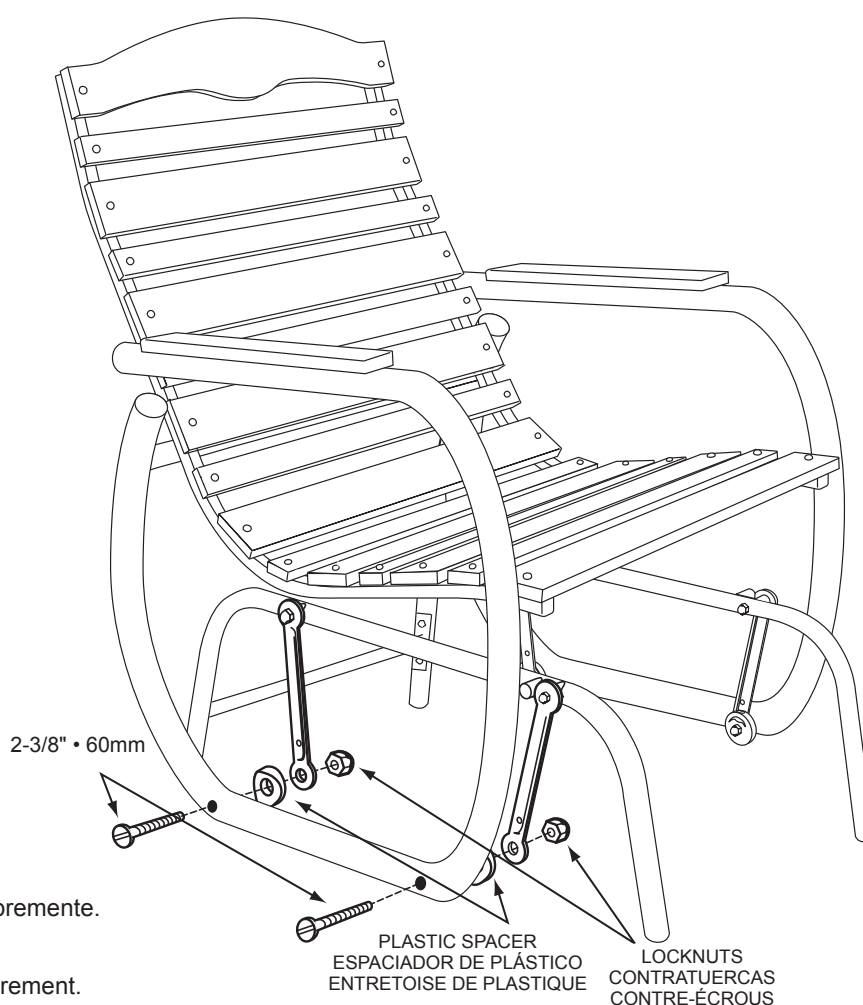

Do not overtighten!
Bearing should move freely.

¡No apriete en exceso!
El rodamiento debe moverse libremente.

Ne resserrez pas trop !
Le palier devrait se déplacer librement.

! **WARNING:** Assemble the seat to the base with the rear base brace behind the seat as shown. If the rear base brace is under the front of the seat, the product can tip over backwards and cause serious injury.

! **ADVERTENCIA:** Arme el asiento a la base dejando el tirante trasero de la base en la parte posterior del asiento como se muestra. Si el tirante trasero de la base queda debajo del frente del asiento, la mecedora puede caerse hacia atrás y provocar lesiones graves.

! **AVERTISSEMENT :** Assemblez le siège à la base avec le renfort arrière de la base derrière le siège tel qu'illustré. Si le renfort arrière de la base est sous l'avant du siège, le fauteuil pourrait basculer vers l'arrière et causer de graves blessures.

STEP 5 Open blister card and plastic parts bag PP-4300.

Attach tray support braces and tray boards using hardware shown.
TIGHTEN HARDWARE.

PASO 5

Una los tirantes de soporte de las bandejas y las tablas de la bandeja usando la ferretería que se muestra.
APRIETE LA FERRETERÍA.

ÉTAPE 5

Fixez les renforts de support du plateau et les planches du plateau avec la quincaillerie indiquée.
RESSERREZ LA QUINCAILLERIE.

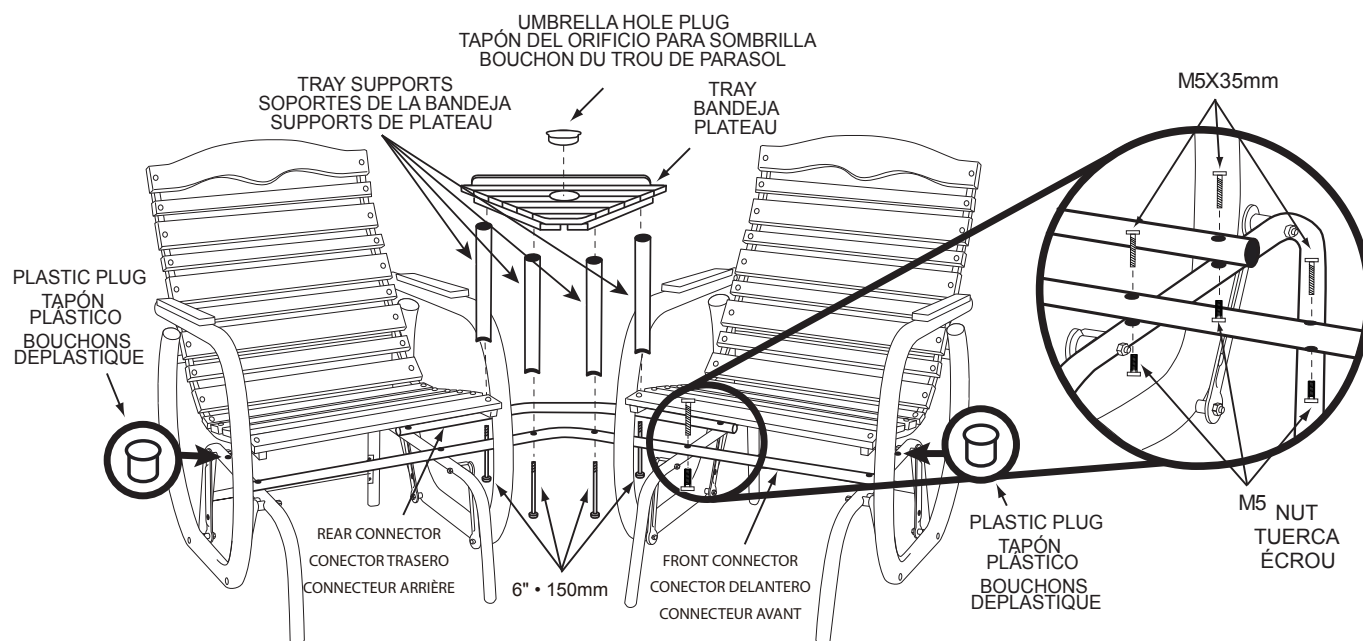

Customer Service

Questions, problems, missing parts?
Please call Customer Service:1-800-800-4950



For more information about warranty, please visit WWW.JACK-POST.COM / Warranty .

JACK-POST[®]
CORPORATION
800 East Third Street
Buchanan, Michigan 49107-1803
Customer Service 1-800-800-4950
Mon. thru Fri. 8:00am – 8:00pm EST
E-mail cs@jack-post.com
English, Español, Français