

USE AND CARE GUIDE

Country Garden® Glider with Trays

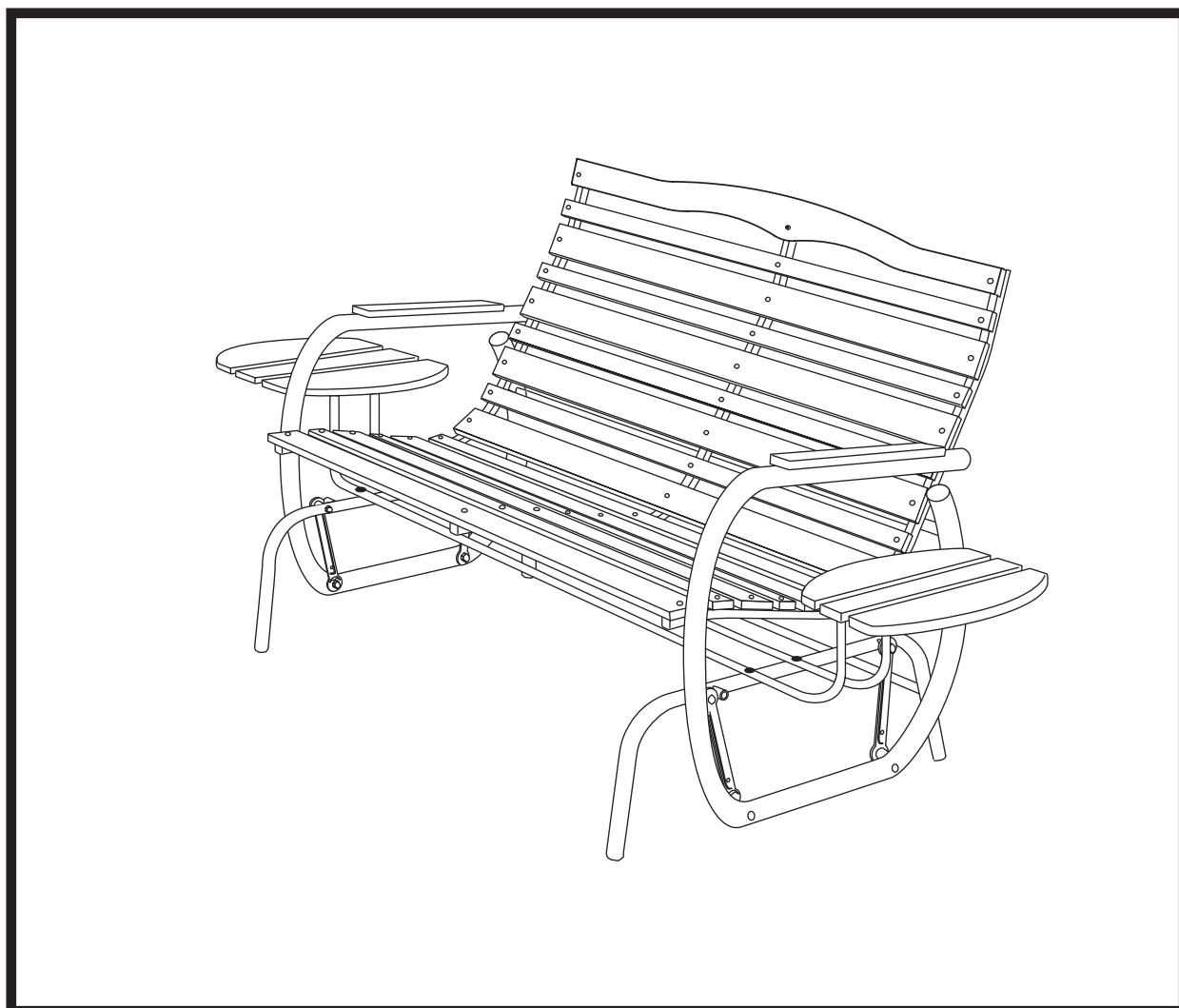

Questions, problems, missing parts?
Please call Customer Service: 1-800-800-4950

warranty



Contents

| | |
|------------------------------------|----|
| Do Not Return | 03 |
| Use & Care /Wood Care Guide..... | 04 |
| Instructions | 05 |
| Customer Service Contact Info..... | 14 |

DO NOT RETURN THIS ITEM TO THE STORE

If you experience any difficulty with assembly, missing parts or use,
please **DO NOT** return this item to the store.

Retail stores are unable to properly assist you.

Contact our **Customer Service Department** directly for assistance.

Call toll-free **1-800-800-4950**, Monday-Friday, between
the hours of 8 a.m. and 8 p.m. (EST).

Our friendly Customer Service Agents will be happy to assist you.

USE & CARE

WARNINGS:

THIS PRODUCT DESIGNED FOR A MAXIMUM CAPACITY OF 500 POUNDS.

NOTE: Save assembly instruction sheet for future reference.

OIL-BASED PAINTED WOOD CARE GUIDE

PLEASE READ THIS INFORMATION CAREFULLY - IT WILL HELP YOU TO MAINTAIN YOUR FURNITURE

This furniture has been made from seasoned wood and has already been factory primed and finished with an oil-based paint. With proper maintenance, it will give you years of enjoyable service. Wood is a natural material and its appearance will change when exposed to the elements; surface splits and checking may appear, particularly on the end grain and to a lesser extent on the surface within a few weeks if left exposed to the elements. The furniture is designed with this in mind to remain strong and durable. If left exposed to the weather, your furniture will fade in color. The exact color will depend on the environment; for example, less fading will occur if the furniture is placed in a shady location under a tree. To help preserve the color, cover the furniture with a garden furniture cover when not in use. Wood expands and contracts with changes in relative humidity. To prevent over drying and excessive cracking, do not store in a heated place.

CARE AND MAINTENANCE

1. We recommend cleaning the surface of dirt, bird droppings, tree sap, grease, etc. Scrub with a cloth or soft brush using a mild household cleaner, dish or laundry detergent.
2. Rinse thoroughly.
3. Allow to dry completely and retighten all hardware.

REFINISHING

Based on exposure to the elements the finish may need to be restored. Proceed as follows:

1. Cover the floor area with a suitable liquid resistant ground sheet to contain dust, dirt or spills.
2. Use suitable protective clothing, i.e., rubber gloves, apron, safety glasses, dust mask, etc.
3. Check and retighten all furniture hardware
4. Remove any finish that has become loose or cracked by using a scraper or wire brush. DO NOT USE STEEL WOOL as the fine particles may result in dark rusty blotching.
5. In a well-ventilated area or outdoors, lightly sand using 100-200 grit sand paper.
6. Remove any dust by wiping with a damp cloth.
7. Allow item to dry completely.
8. Use an oil-based primer on any bare wood spots.
9. Brush or spray on new finish using the manufacturer's instructions – using an oil-based paint available at any paint retailer.

Country Garden® Glider with Trays
Mecedora con bandejas Backyard Creations®
Fauteuil coulissant à plateaux Backyard Creations®

Assembly Instructions – Model CG-12
Instrucciones de armado – Modelo CG-12
Instructions d'assemblage – Modèle CG-12

Open outer hardware bag HB-4500 & Blister card . Do not open inner bags until instructed.

Abra la bolsa exterior de ferretería HB-4500 & Tarjeta blister . No abra las bolsas internas hasta que se le indique.

Ouvrez le sac de quincaillerie extérieure HB-4500 & Carte plastifiée . N'ouvrez pas les sacs intérieurs avant que ceci ne soit indiqué.

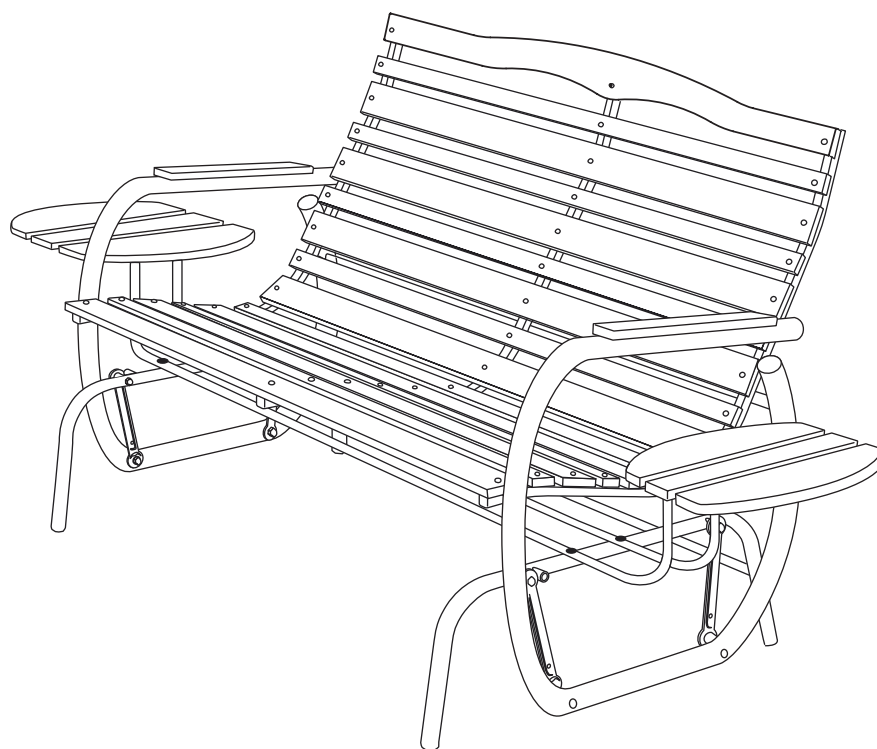

IMPORTANT

UNLESS NOTED, DO NOT TIGHTEN ANY BOLTS UNTIL LAST STEP.

IMPORTANTE

A MENOS QUE SE LE INDIQUE, NO APRIETE NINGÚN PERNO HASTA EL ÚLTIMO PASO.

IMPORTANT

À MOINS D'INDICATION CONTRAIRE, NE RESSERREZ PAS LES BOULONS AVANT LA DERNIÈRE ÉTAPE.

TOOLS . HERRAMIENTAS . OUTIL

You will need the following tools: screwdriver, 7/16" wrench, or pliers or adjustable wrench.

Necesitará las siguientes herramientas: destornillador, llave de 1,11 cm, o pinza o llave ajustable.

Vous aurez besoin des outils suivants : tournevis, clés de 1,11 cm, ou pinces ou clé réglable.

LARGE PARTS (NOT TO SCALE)

PIEZAS GRANDES (NO A ESCALA)

PIÈCES GRANDES (PAS À L'ÉCHELLE)



SHAPED TOP SLAT (1)
LISTÓN SUPERIOR MODELADO (1)
LATTE SUPÉRIEURE FORMÉE (1)

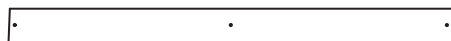

WIDESLAT(7)
LISTÓN ANCHO(7)
LATTE LARGE(7)

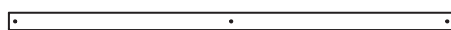

NARROW SLAT (7)
LISTÓN ANGOSTO (7)
LATTE ÉTROITE (7)

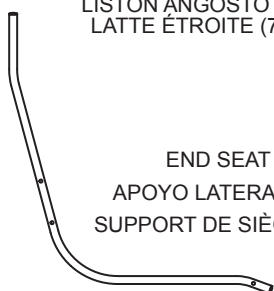

END SEAT SUPPORT (2)
APOYO LATERAL DEL ASIENTO (2)
SUPPORT DE SIÈGE D'EXTRÉMITÉ (2)

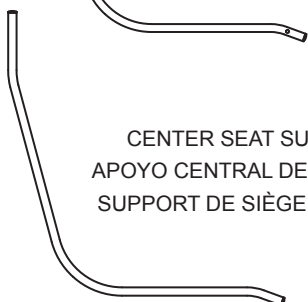

CENTER SEAT SUPPORT (1)
APOYO CENTRAL DEL ASIENTO (1)
SUPPORT DE SIÈGE CENTRAL (1)

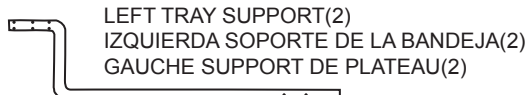

LEFT TRAY SUPPORT(2)
IZQUIERDA SOPORTE DE LA BANDEJA(2)
GAUCHE SUPPORT DE PLATEAU(2)

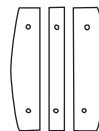

TRAYS (2)
BANDEJAS(2)
PLATEAUX(2)

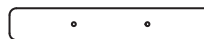

ARMREST (2)
APOYO DEL POSABRAZOS (2)
ACCOUDOIR (2)

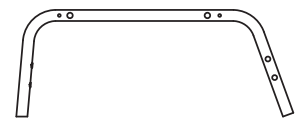

BASE(2) BASE(2) BASE(2)

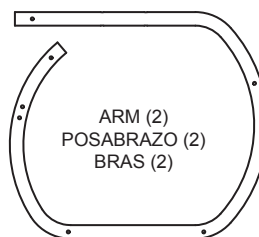

ARM (2)
POSABRAZO (2)
BRAS (2)



BEARING (4)
RODAMIENTO (4)
ROULEMENT(4)

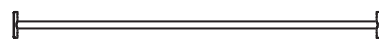

REAR BASE BRACE(1)
TIRANTE DELA BASE TRASERO (1)
RENFORT DELA BASE ARRIÈRE (1)

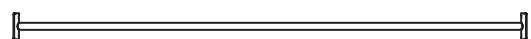

SEAT BRACE (1)
TIRANTE DEL ASIENTO (1)
RENFORT DU SIÈGE (1)



RIGHT TRAY SUPPORT(2)
DERECHA SOPORTE DE LA BANDEJA(2)
DROITE SUPPORT DE PLATEAU(2)

HARDWARE PARTS LIST (SHOWN TO SCALE)

*Standard hardware items may be replaced locally.

LISTA DE PIEZAS DE FERRETERÍA (SE MUESTRAN A ESCALA)

*Los artículos estándar de ferretería se pueden reemplazar en forma local.

LISTE DE PIÈCES DE QUINCAILLERIE (À L'ÉCHELLE)

*Les articles de quincaillerie standard peuvent être remplacés localement.

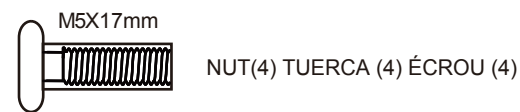
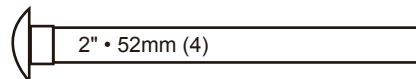
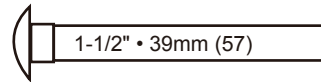
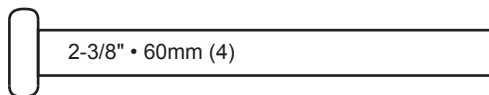
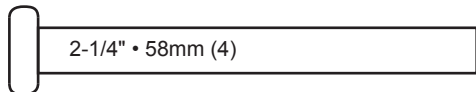
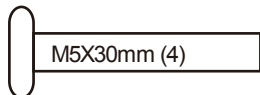
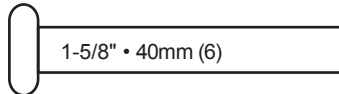
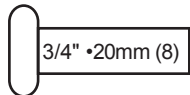
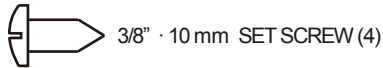

TOOLS INCLUDED (NOT TO SCALE)

HERRAMIENTAS INCLUIDAS (NO A ESCALA)

OUTIL INCLURE (PAS À L'ÉCHELLE)



STEP 1A Open blister card and plastic parts bag PP-4400 .

Attach base braces to bases with hardware shown.
The base braces are shorter than the seat brace.

PASO 1 A

Instale los tirantes de la base a las bases con la ferretería que se muestra.
Instale los topes de la mecedora a las bases con la ferretería que se muestra.

ÉTAPE 1A

Fixez les cales de base aux bases avec la quincaillerie indiquée.
Fixez les butées de patin aux bases avec la quincaillerie indiquée.

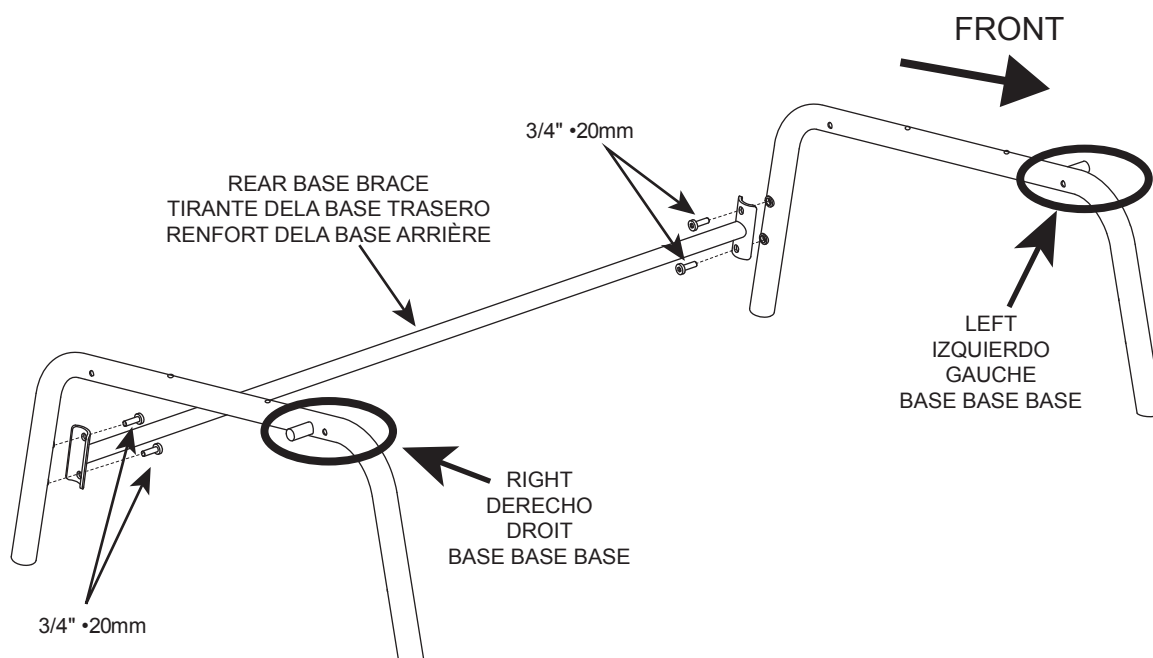
**STEP 1B**

Attach bearing assemblies to base using hardware and plastic spacers shown.
TIGHTEN ALL HARDWARE IN STEP 1A AND 1B.

PASO 1 B

Instale los ensambles de los rodamientos a la base usando la ferretería y los separadores plásticos que se muestran.
APRIETE TODA LA FERRETERÍA EN EL PASO 1A Y 1B.

ÉTAPE 1B

Fixez les assemblages de roulement à la base avec la quincaillerie et les entretoises de plastique indiquées.
RESSEREZ LA QUINAILLERIE DES ÉTAPES 1A Y 1B.

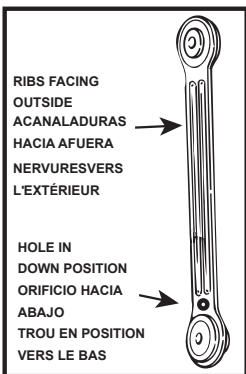
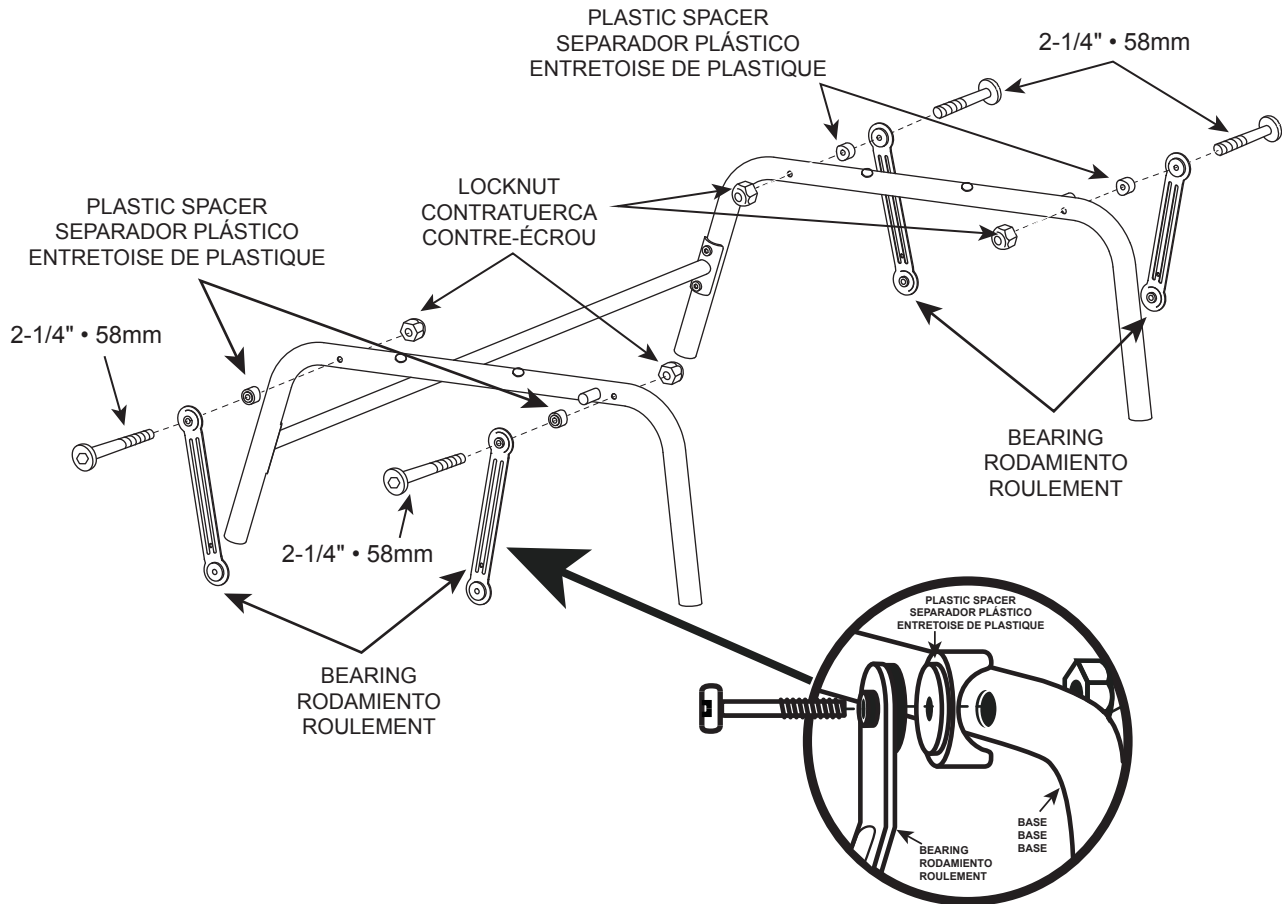

IMPORTANT NOTE:
 On both sides of the glider, the two (2) protruding ribs on the bearing assembly must face outward and the hole must be at the bottom.

NOTA IMPORTANTE:
 En ambos lados de la mecedora, las 2 (dos) acanaladuras que sobresalen en el ensamble del rodamiento deben estar hacia afuera y el orificio debe estar en la parte inferior.

REMARQUE IMPORTANTE :
 Des deux côtés du patin, les deux (2) nervures sortantes sur l'assemblage de roulement doivent faire face vers l'extérieur et le trou doit être au bas.

Do not overtighten! Two (2) threads should extend beyond the nylon in the end of the nut. Bearing should move freely.

¡No apriete en exceso!
 Deben quedar 2 (dos) roscas sobresaliendo del nilón en el extremo de la tuerca. El rodamiento debe moverse libremente.

Ne resserrez pas trop !
 Deux (2) filets doivent sortir au-delà du nylon à la fin de l'écrou. Le roulement doit se déplacer librement.

STEP 2 Open blister card , inner hardware bag IB-4501 and plastic parts bag PP-4400.

Attach 2 arm rests with hardware shown. Attach seat brace to arms using hardware shown. Attach end seat supports to arms with hardware shown. The end seat supports have 3 holes on the side. The center seat support does not have side holes.
DO NOT TIGHTEN HARDWARE.

PASO 2

Una los 2 apoyos de los posabrazos con la ferretería que se muestra. Una el tirante del asiento a los posabrazos con la ferretería que se muestra. Una los apoyos laterales del asiento a los posabrazos con la ferretería que se muestra. Los apoyos laterales del asiento tienen 3 orificios al costado. El apoyo central del asiento no tiene orificios laterales.
NO APRIETE LA FERRETERÍA.

ÉTAPE 2

Fixez les 2 accoudoirs avec la quincaillerie indiquée. Fixez le renfort du siège aux accoudoirs avec la quincaillerie indiquée. Fixez les supports d'extrémité du siège aux bras avec la quincaillerie indiquée. Les supports d'extrémité du siège ont 3 trous sur le côté. Le support du siège central n'a pas de trous latéraux.

NE RESSERREZ PAS LA QUINCAILLERIE.

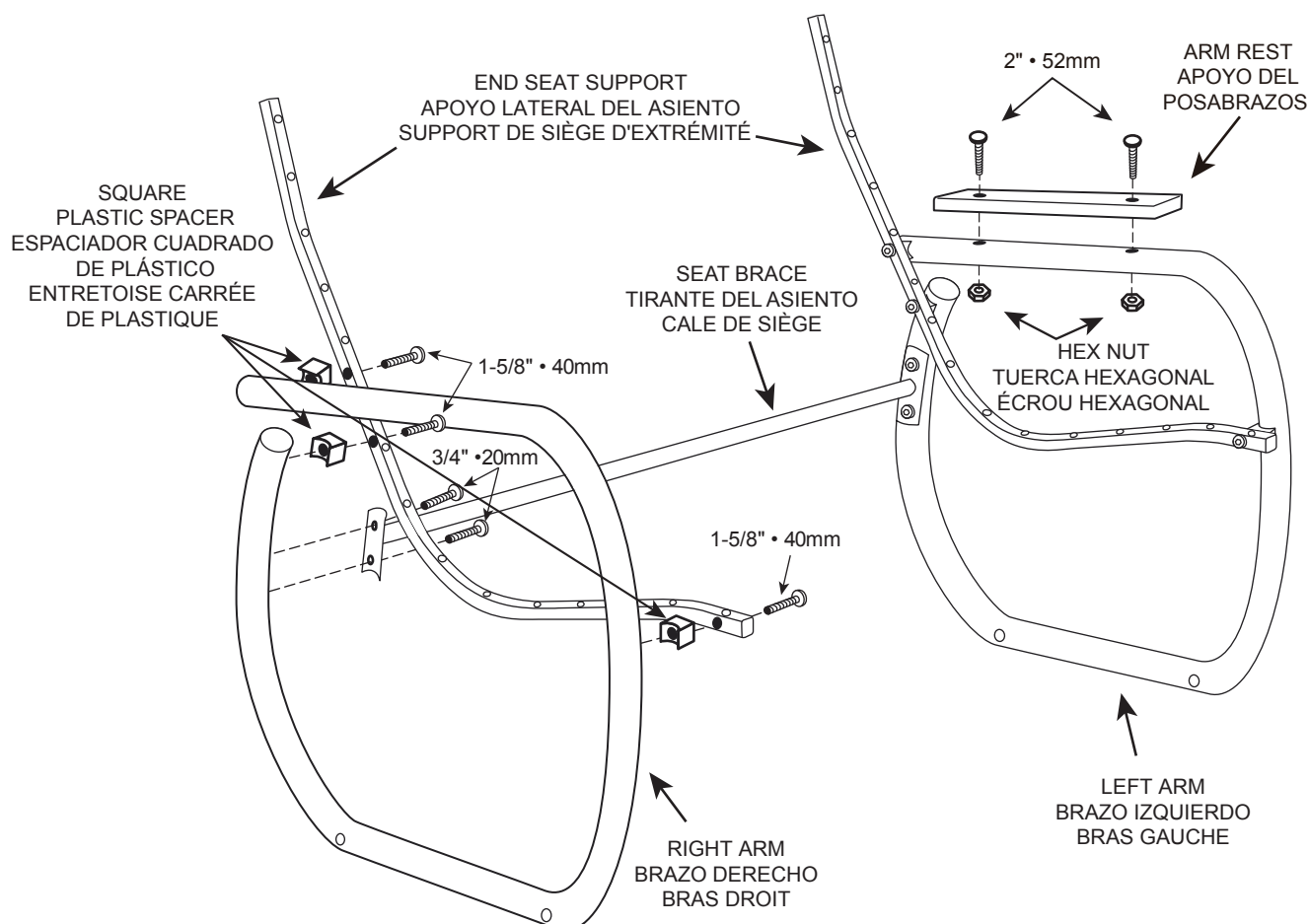

STEP 3 Open inner hardware bag IB-4050 .

Attach the shaped top seat slat to the top of the 3 seat supports and a slat to the front using the hardware shown. Tap bolt heads into holes in slats until fully seated. Fasten the top 9 slats on all 3 seat supports with acorn nuts and the bottom 6 with hex nuts.

MAKE SURE THE ASSEMBLY IS SQUARE. TIGHTEN ALL HARDWARE.

PASO 3

Una el listón superior modelado del asiento a la parte superior de los 3 apoyos del asiento y un listón al frente usando la ferretería que se muestra. Golpee las cabezas de los pernos en los orificios de los listones hasta que estén totalmente asentadas. Ajuste los 9 listones superiores en los 3 apoyos del asiento con tuercas ciegas y los 6 inferiores con tuercas hexagonales.

ASEGÚRESE DE QUE EL ENSAMBLE ESTÉ EN ESCUADRA. APRIETE TODA LA FERRETERÍA.

ÉTAPE 3

Fixez la latte supérieure du siège formée sur le dessus des 3 supports du siège et une latte à l'avant avec la quincaillerie indiquée. Taraudez les têtes des écrous dans les trous des lattes jusqu'à ce qu'elles soient bien installées. Fixez les 9 lattes supérieures sur les trois supports du siège avec les écrous borgnes et les 6 du bas avec les écrous hexagonaux.

ASSUREZ-VOUS QUE L'ASSEMBLAGE SOIT D'ÉQUERRE. RESSERREZ TOUTE LA QUINCAILLERIE.

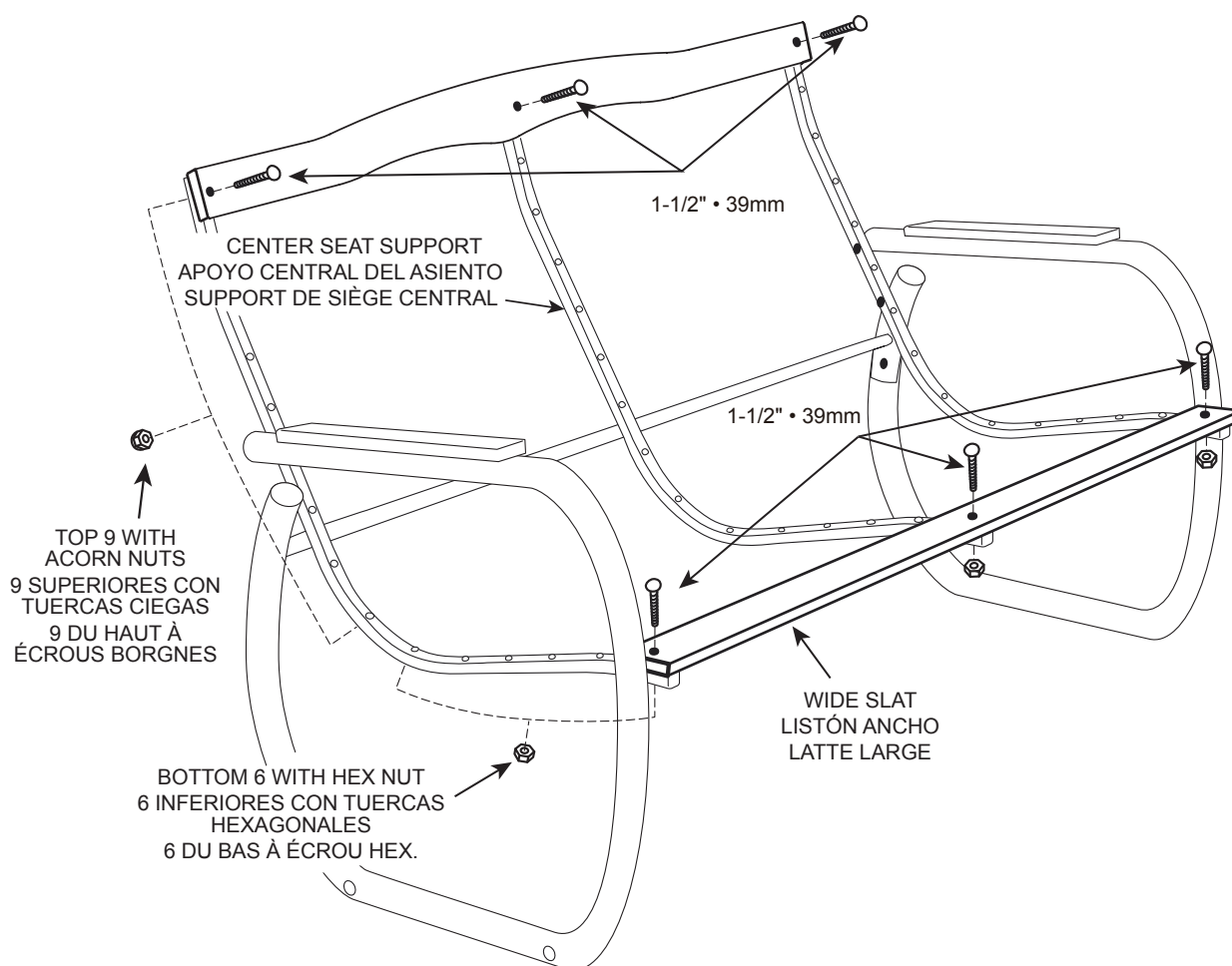

STEP 4 Open blister card and plastic parts bag PP-4400.

Attach seat to base using hardware shown.
TIGHTEN HARDWARE.

PASO 4



Una el asiento a la base usando la ferretería que se muestra.
APRIETE LA FERRETERÍA.

ÉTAPE 4

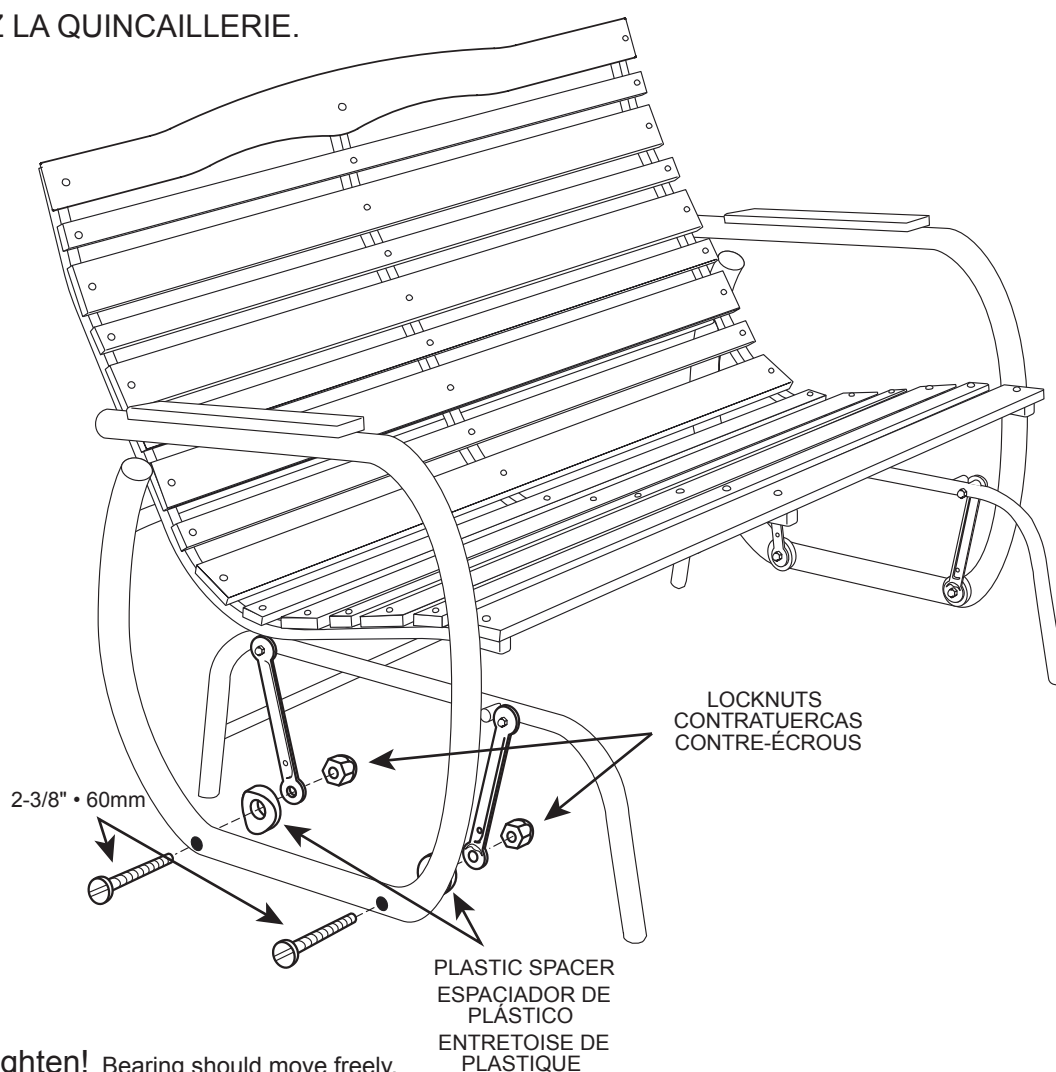
Fixez le siège à la base avec la quincaillerie indiquée.
RESSERREZ LA QUINCAILLERIE.



Do not overtighten! Bearing should move freely.
¡No apriete en exceso! El rodamiento debe moverse libremente.
Ne resserrez pas trop ! Le palier devrait se déplacer librement.

-  **WARNING:** Assemble the seat to the base with the rear base brace behind the seat as shown. If the rear base brace is under the front of the seat, the product can tip over backwards and cause serious injury.
-  **ADVERTENCIA:** Arme el asiento a la base dejando el tirante trasero de la base en la parte posterior del asiento como se muestra. Si el tirante trasero de la base queda debajo del frente del asiento, la mecedora puede caerse hacia atrás y provocar lesiones graves.
-  **AVERTISSEMENT :** Assemblez le siège à la base avec le renfort arrière de la base derrière le siège tel qu'illustré. Si le renfort arrière de la base est sous l'avant du siège, le fauteuil pourrait basculer vers l'arrière et causer de graves blessures.

STEP 5 Open blister card , inner hardware bag IB-4501 and plastic parts bag PP-4400.

Attach tray support braces and tray boards using hardware shown.
TIGHTEN HARDWARE.

PASO 5

Una los tirantes de soporte de las bandejas y las tablas de la bandeja usando la ferretería que se muestra.
APRIETE LA FERRETERÍA.

ÉTAPE 5

Fixez les renforts de support du plateau et les planches du plateau avec la quincaillerie indiquée.
RESSERREZ LA QUINCAILLERIE.

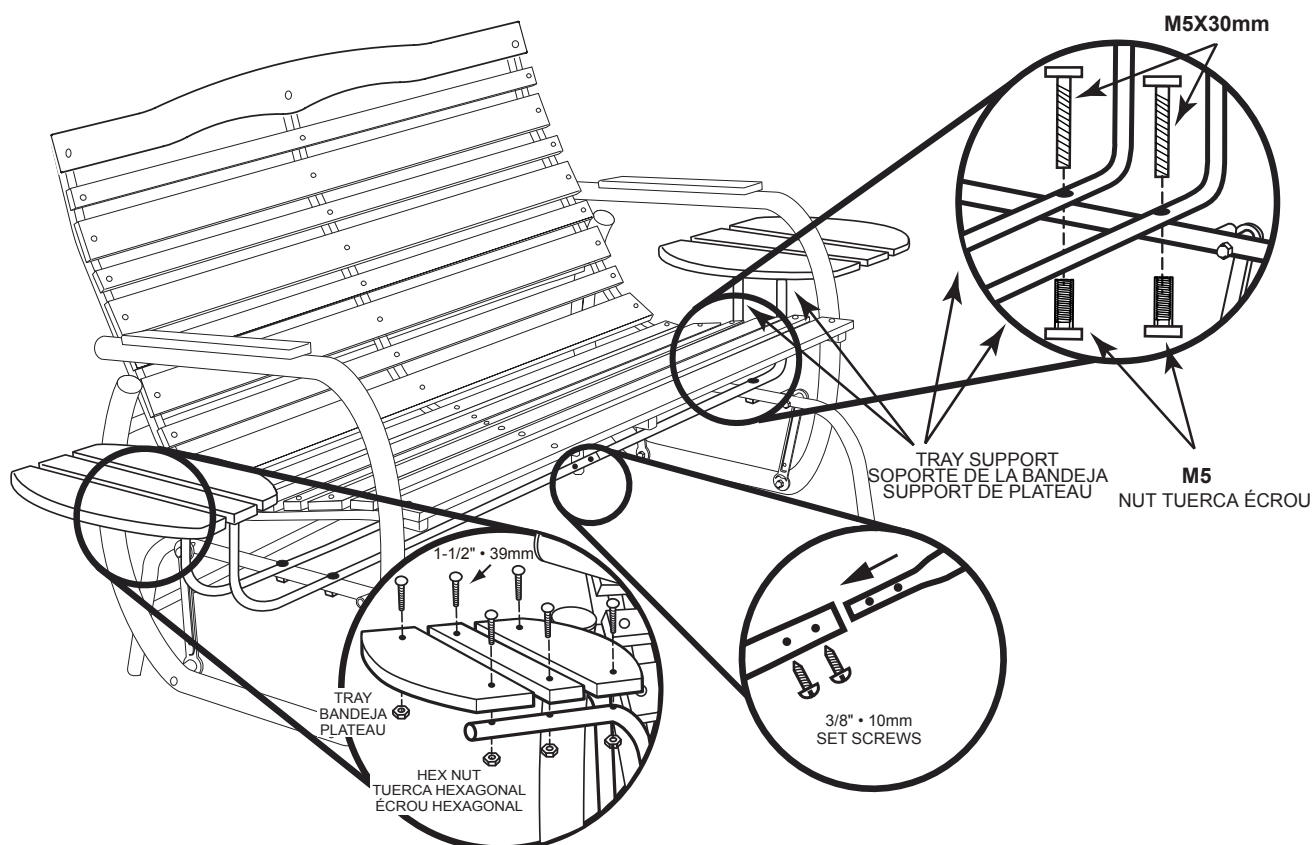

Customer Service

Questions, problems, missing parts?
Please call Customer Service: 1-800-800-4950



For more information about warranty, please visit WWW.JACK-POST.COM / Warranty .

JACK-POST[®]
CORPORATION
800 East Third Street
Buchanan, Michigan 49107-1803
Customer Service 1-800-800-4950
Mon. thru Fri. 8:00am – 8:00pm EST
E-mail cs@jack-post.com
English, Español, Français